



TANKLESS

PRODUCT GUIDE

TABLE OF CONTENTS

Tankless Advantage.....	2
Simple Tankless Sizing.....	3
Safety.....	4
Flow Rate Guide	5
Basic Sizing Guidelines	6
Overcoming Hard Water Scale.....	7-8
Durability	9
Valves and Water Flow.....	10

RESIDENTIAL CONDENSING

Residential Condensing with X3 Scale Prevention Technology.....	11-14
Residential Condensing with Integrated Recirculation (540P Models).....	15-16
Residential Condensing (240H, 340H, 540H Models).....	17-20
Residential Condensing (140H Models)	21-22

RESIDENTIAL NON-CONDENSING

Residential Non-Condensing Ultra-Low NOx	23-26
Residential Non-Condensing Concentric Vent	27-30

RESIDENTIAL COMBI BOILER

Domestic Hot water and Space Heating How it Works.....	31
Combi Boiler Flow Rate Guide	32
Residential Combi Boiler.....	33-34

COMMERCIAL NON-CONDENSING

Commercial Non-Condensing	35-36
---------------------------------	-------

COMMERCIAL CONDENSING

Commercial Condensing	37-38
-----------------------------	-------

COMMERCIAL TANKLESS RACK SYSTEM

Tankless Configurations	39
Multi-Units Systems	40

TANKLESS APPLICATION DIAGRAMS

Basic Installation.....	41
540P Basic Installation.....	41
Multiple Units	42-43
Solar Tankless Back Up.....	44

VENTING AND ACCESSORIES

Solar Tankless Back Up Diagrams.....	45
Venting Diagrams	46-47
Direct Vent Concentric Sidewall Termination	48-51
Concentric Vent Series.....	52-53
Venting Components.....	54-55
Accessories	56
Product Overview.....	57-58

TANKLESS ADVANTAGE

How It Works – The Process:

- A hot water tap is opened.
- The opened tap allows water to flow through the water heater. An internal water flow sensor detects this flow.
- Upon flow detection, the flow sensor sends the activation signal to the computer board.
- The computer automatically ignites the burner.
- As water flows through the heat exchanger, it absorbs heat from the burner.
- By the time the water exits the heater, it has reached the designated set temperature.
- When the hot water tap is closed, the water heater automatically turns off.

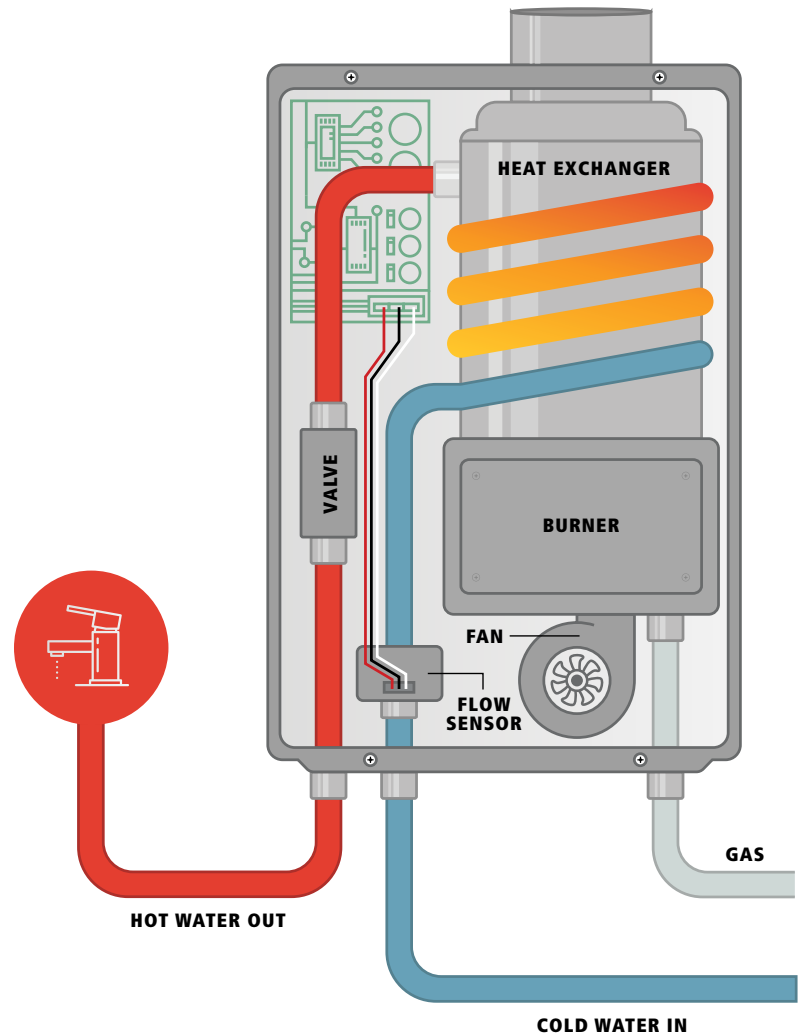

Endless Hot Water

Heating water only as it's being used means you will never run out of hot water again. After the few seconds it takes for the water to reach the designated set temperature, our water heaters will continually provide a steady flow of hot water for as long as your application needs it (when sized appropriately for your home's needs).

Energy Conservation

Provides you with continuous hot water in one of the most energy-efficient ways possible. Conventional tank-type water heaters will heat and store a set volume of water, regardless of whether someone is using that hot water or not. Because our tankless water heaters only activate when hot water is being used, no standby energy losses are incurred, providing efficient heating while conserving energy.

Compact Size

On top of all this, an A. O. Smith tankless water heater takes up much less space than your conventional tank-type water heater or boiler. A. O. Smith's wall-mount design offers flexible installations freeing up valuable storage space.

SIMPLE TANKLESS SIZING



AVERAGE GROUND WATER TEMPERATURE

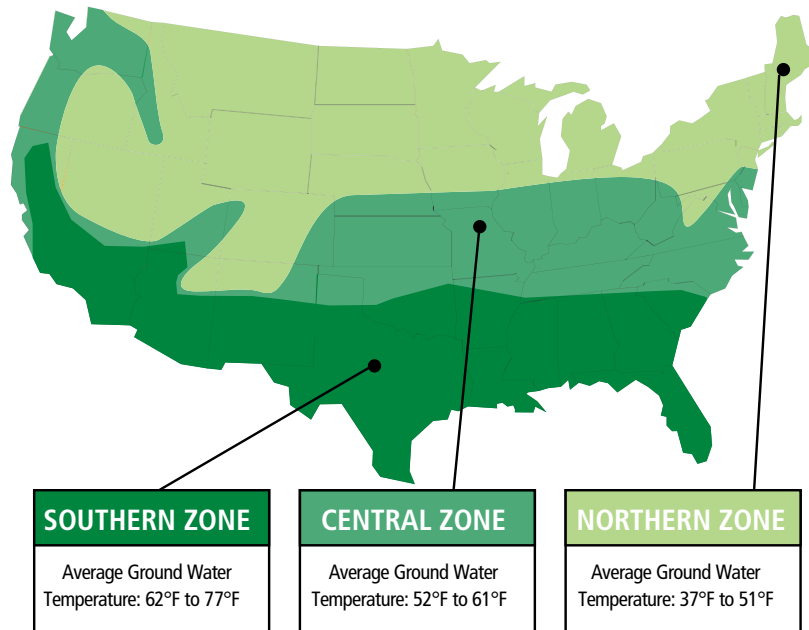

Remember, these are general recommendations. Your A. O. Smith Water Heater Specialist can review your family's needs in even greater detail to make sure the model you choose will always provide enough hot water to meet the demand.

Tankless Models Ground Water Temperature Factor

The temperature of incoming ground water (cold water inlet temperature) varies greatly throughout the U.S. and also fluctuates with the changing of the seasons. The temperature of water as it enters the water heater will determine the amount of "temperature rise" required to achieve the desired hot water outlet temperature (120°F is recommended). The best way to measure incoming ground water temperature is to use a thermometer to measure cold water temperature during the coldest season of the year. To simplify the process, use this map to determine whether your installation location is in the Southern Zone, Central Zone or Northern Zone.

Peak Hot Water Demand

The next step is to determine how many gallons per minute of hot water will be required during the busiest usage period (peak demand). Consider all appliances and fixtures that use hot water, including lavatory faucets, kitchen faucets, washing machines, dishwashers, showers and bathtubs. Be sure to determine how many appliances and fixtures will be used at the same time (peak demand).

SAFETY

At A. O. Smith, we place the safety and reliability of our products above all else. By incorporating technologically advanced safety features into every model, we provide the assurance and peace of mind that can only come from an A. O. Smith quality product.

Air-Fuel Ratio (AFR) Sensor

A. O. Smith's unique AFR sensor monitors and maintains proper combustion at all times. Together with the onboard computer, this system will adjust the fan motor speed to ensure that air and fuel have a proper mixture ratio, minimizing emissions and maximizing efficiency.

Additional Safety Features

Freeze Protection:

Every heater in A. O. Smith's tankless lineup has an internal freeze protection system, which is rated to protect the heaters when installed in sub-freezing conditions. This system works to keep water temperatures within the heat exchanger from falling below a certain level, preventing freeze damage.

Hi-Limit Switch:

Ensures that water temperatures do not exceed safe levels. Before the water temperature can even reach these unsafe levels, the hi-limit switch activates by disengaging the gas valves, effectively shutting down the water heater.

PVC Venting:

Indoor condensing models have a thermistor and hi-limit switch that monitor the exhaust temperature. If the exhaust temperature nears an unsafe limit, these features regulate combustion and can shut the heater down to protect the integrity of the PVC vent material.

Overheat Cutoff Fuse:

Ensures that there are no breaches in the heat exchanger drum. In cases where enough physical damage might have been done to the water heater to lead to a breach in the heat exchanger drum, the overheat cutoff fuse reacts by shutting down the water heater if the surface of the heat exchanger retains too much heat.

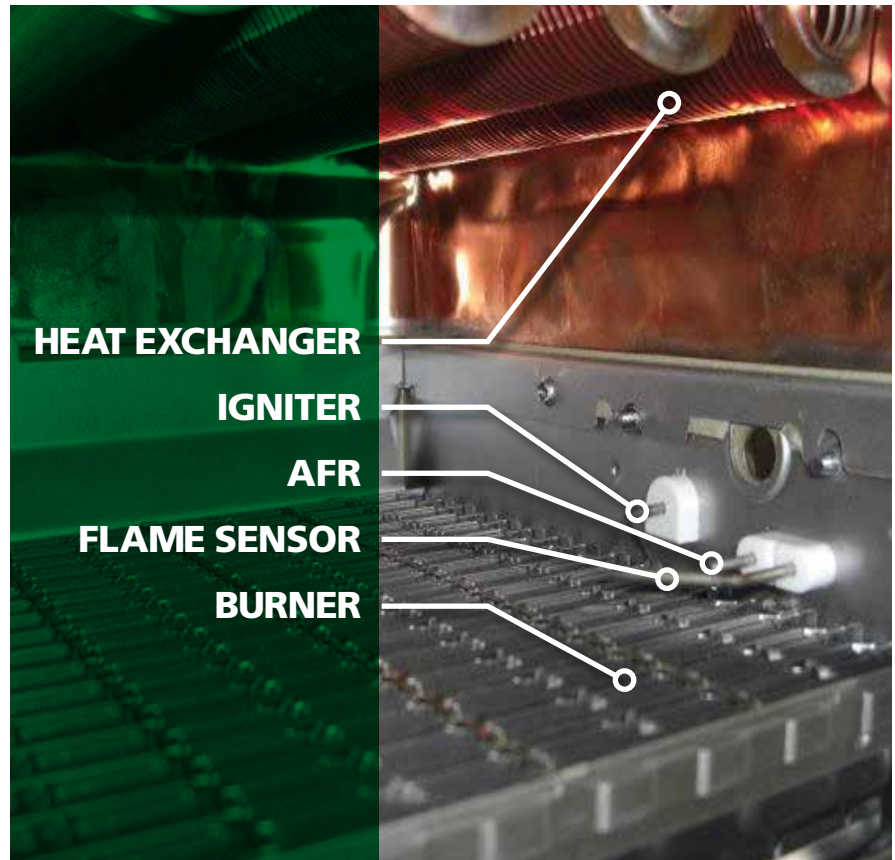

FLOW RATE GUIDE

Temperature Rise vs. Gallons per Minute

Temp Rise	110U	310U/C	510U/C	140H	240H/240X3	340H/340X3	540H/P/ 540X3	CT-199	910
30°	6.6	8.0	10.0	6.6	6.6	8.0	10.0	10.0	14.5
35°	6.6	8.0	9.3	6.4	6.6	8.0	10.0	10.0	14.5
40°	5.7	7.8	8.1	5.6	6.6	8.0	9.5	9.5	14.5
45°	5.1	6.9	7.2	5.0	6.6	7.6	8.4	8.4	13.5
50°	4.6	6.2	6.5	4.5	6.1	6.8	7.6	7.6	12.2
55°	4.2	5.7	5.9	4.1	5.5	6.2	6.9	6.9	11.1
60°	3.8	5.2	5.4	3.7	5.1	5.7	6.3	6.3	10.1
65°	3.5	4.8	5.0	3.4	4.7	5.3	5.8	5.8	9.4
70°	3.3	4.4	4.7	3.2	4.3	4.9	5.4	5.4	8.7
75°	3.1	4.1	4.3	3.0	4.1	4.6	5.0	5.0	8.1
80°	2.9	3.9	4.1	2.8	3.8	4.3	4.7	4.7	7.6
85°	2.7	3.7	3.8	2.6	3.6	4.0	4.4	4.4	7.2
90°	2.5	3.5	3.6	2.5	3.4	3.8	4.2	4.2	6.8
95°	2.4	3.3	3.4	2.3	3.2	3.6	4.0	4.0	6.4
100°	2.3	3.1	3.3	2.2	3.0	3.4	3.8	3.8	6.1

Flow rate is determined by temperature rise. To determine your temperature rise, subtract the incoming water temperature from the set output temperature. All units are factory set to 120°F or 122°F but can be changed.

Example of Hunter Curves for Sizing Large Applications

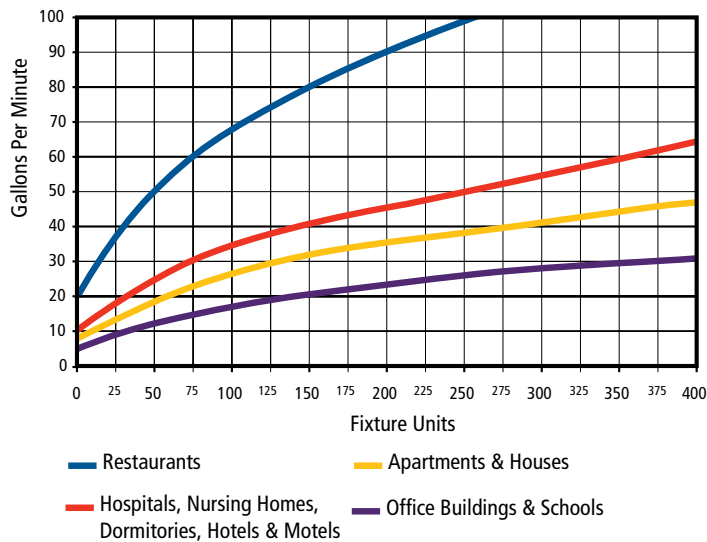

Comparison of Flow Rates vs. Temperature Rise

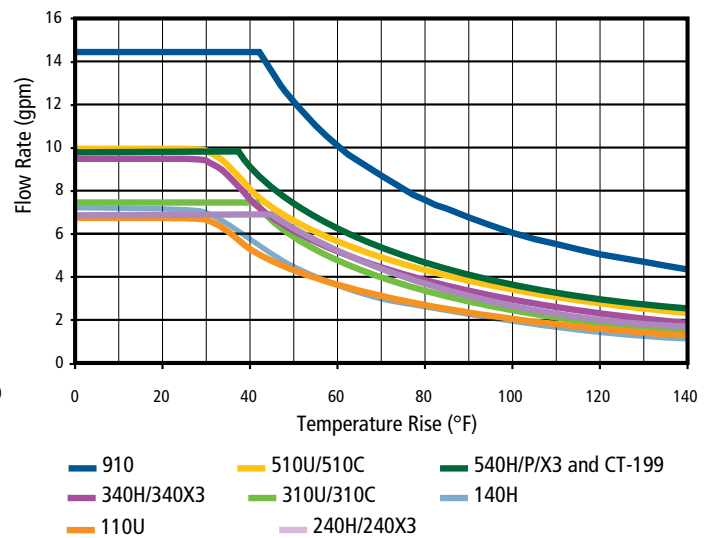

BASIC SIZING GUIDELINES

The flow rate capacity of tankless water heaters depends on the temperature difference between the desired output and incoming water temperature. The flow rate comparison chart and table shown here summarize the flow rate charts found in the specifications of each model.

A. O. Smith water heaters are sized according to the peak flow rate requirements, worst-case temperature-rise scenarios, and types of applications. Once these factors have been determined, refer to either the flow rate comparison here or the flow rate charts found in each model's specifications. Select the appropriate water heater as well as the amount of water heaters required.

Application designers/engineers can decide whether to size for full flow, expected flow, or utilize probability models such as the modified "Hunter Curve." For large scale applications such as hotels, apartment complexes and large restaurants, Hunter Curves are commonly used to estimate the peak flow rate demand when given the total amount of fixture units within an application. It is up to the application designer/engineer to determine the amount of fixture units within any given application.





Match the Unit to Your Needs

Warmer Climates
70°F Incoming Groundwater Temperature



Cooler Climates
50°F Incoming Groundwater Temperature

Capacity - Number of Shower Heads (Assuming the set point temperature is 120°F)



Condensing Units

540H/P/X3	4.5 Showers	
340H/340X3	4 Showers	
240H/240X3	3.5 Showers	
140H	2.5 Showers	

Non-Condensing Units

510U/C	3.5 Showers	
310U/C	3.5 Showers	
110U	2.5 Showers	

Commercial Units

910	7 Showers	
CT-199	4.5 Showers	

3 Showers	
2.5 Showers	
2.5 Showers	
1.5 Showers	
2.5 Showers	
2.5 Showers	
1.5 Showers	
5 Showers	
3 Showers	

OVERCOMING HARD WATER SCALE

Hard water is everywhere. In fact, more than 85% of American homes have hard water which adversely affects plumbing systems, including water piping, water fixtures and the water heating system.

What is hard water and hard water scale?

Water is classified as "hard" when it has a high mineral content, specifically magnesium and calcium (Ca^{2+} and Mg^{2+} ions). Hard water is not considered a health risk and these minerals generally remain dissolved in the water. However, problems arise when the minerals precipitate out of the water and leave behind a solid mineral buildup. This buildup, called scale, reduces water flow through pipes and fixtures, reduces the energy efficiency of water heating equipment and causes damage to the heat exchangers within tankless water heaters. Scale formation is based on water hardness levels and the temperature, not on the material the scale is adhering to. For example, hard water scale would form equally on a copper surface as it would on a stainless steel surface, given the same hardness level and temperature of water.

What does hard water scale do to my water heater?

Scale is the number one threat to tankless water heaters where it reduces energy efficiency and damages the heater. When hard water scale forms a layer coating on the inside wall of a tankless heat exchanger fin pipe, it acts as a thermal insulator. This insulation effectively prevents a significant amount of heat from the burners to properly transfer into the water within the piping. Because the heat is not transferring into the water, the heat exchanger material retains this excess heat, eventually overheating and becoming damaged. Once scale forms, scale removal maintenance can be performed, but the heater will never return to peak efficiency. Without scale removal, the heat exchanger piping will eventually leak.

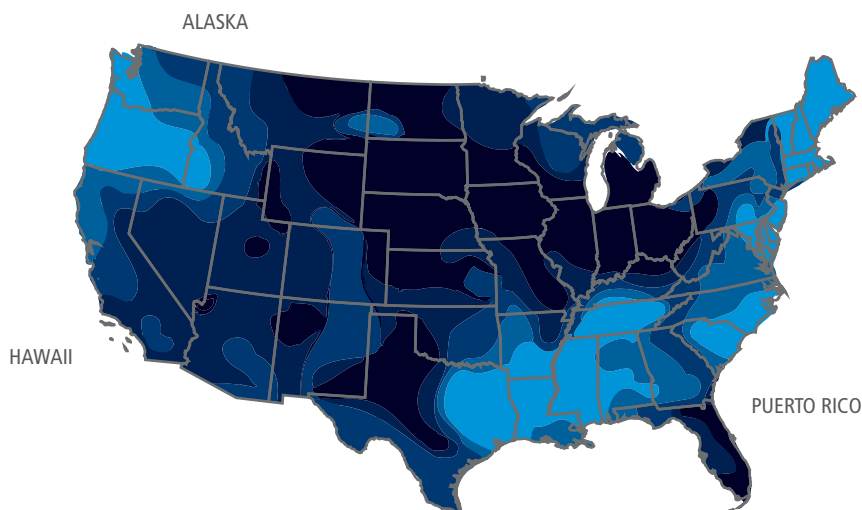

Classification	GPG (Grains Per Gallon)
● Slightly Hard	Less than 3
● Moderately hard	3 to 7
● Hard	7 to 10
● Very Hard	10 to 14
● Extremely Hard	Over 14

The U.S. Department of Interior and the Water Quality Association

How is the hardness of water measured?

Water hardness is measured in either parts per million (ppm) or grains per gallon (gpg). Anything greater than 3 gpg is generally considered hard (United States Geological Survey).

OVERCOMING HARD WATER SCALE

How do I prevent hard water scale?

X3 Scale Prevention Technology

A. O. Smith has combined its expertise in water heating and treatment to create X3® Scale Prevention Technology. By preventing scale from ever forming, this feature extends the life of the unit three times longer than traditional tankless. This makes it the first tankless product that maintains “like-new” performance without requiring any scale-related maintenance.

A. O. Smith stands behind this revolutionary product with the industry’s first ever “Peace of Mind” limited warranty. Unlike competitive warranties, this 15-year limited warranty covers scale-related failures should they occur.

Tankless with X3 Technology

Still running after 19.7 simulated years and 460,000 gallons



Unprotected tankless:

Failed at 5.8 simulated years and 136,000 gallons



Product Preservers®

For applications when X3® Technology is not available, A. O. Smith Product Preservers anti-scale filters protect your tankless water heater from damage due to scale formation. This system does not add chemicals to the water or require electricity. As water flows through the filter, hard water minerals form inactive scale crystals which flow through the water heater without sticking to the heat exchanger.

Product Preservers are not needed for units with X3 Technology. Product Preservers filters are a minimal maintenance solution, which require replacement every two years.

Sizing Chart

Flow Rate Based Ground Water Temperature (assume 120°F Set point)

		Tankless Model	110U	310U/C	510U/C	140H	240H	340H	540H/P	910	CT-199
Ground Water Temperature (°F)	Warmer Climate	85°F	6.6	8	9.3	6.4	6.6	8.0	10.0	14.5	10.0
		80°F	5.7	7.8	8.2	5.6	6.6	8.0	9.5	14.5	9.5
		75°F	5.1	6.9	7.3	5.0	6.6	7.6	8.4	13.5	8.4
		70°F	4.6	6.2	6.5	4.5	6.1	6.8	7.6	12.2	7.6
		65°F	4.2	5.7	5.9	4.1	5.5	6.2	6.9	11.0	6.9
		60°F	3.8	5.2	5.4	3.7	5.1	5.7	6.3	10.1	6.3
	Colder Climate	55°F	3.5	4.8	5.0	3.4	4.7	5.3	5.8	9.4	5.8
		50°F	3.3	4.5	4.7	3.2	4.3	4.9	5.4	8.7	5.4
		45°F	3.1	4.2	4.4	3.0	4.1	4.6	5.0	8.1	5.0
		40°F	2.9	3.9	4.1	2.8	3.8	4.3	4.7	7.6	4.7
	35°F	2.7	3.7	3.8	2.6	3.6	4.0	4.5	7.2	4.5	

100291509 Product Preservers® Anti-Scale System

Requires multiple units



DURABILITY

A. O. Smith tankless products are built with commercial-grade materials to ensure durability and reliability.

Commercial-Grade Copper Alloy

Our commercial-grade copper is a heat-resistant copper alloy, with additive elements that give it eight times the tensile strength of regular copper. Even at high temperatures, our commercial-grade copper maintains a fine grain and high strength. Commercial-grade copper provides resistance to the damaging effects of erosion that can cause heat exchangers to leak.

316L Stainless Steel

A. O. Smith condensing models utilize 316L stainless steel in the secondary heat exchanger. Stainless steel performs well in extreme environments including heat, acidic condensation and chloride.

Drum Thickness

During every ignition cycle, thermal expansion causes all heat exchangers to undergo heat stress. After the thousands of ON/OFF cycles typically seen in a commercial application, this heat stress can prove damaging. This is why the heat exchangers in our commercial and light commercial products utilize drums that are 25% thicker, ensuring the longevity of our products. A thicker drum creates less strain on the heat exchanger.

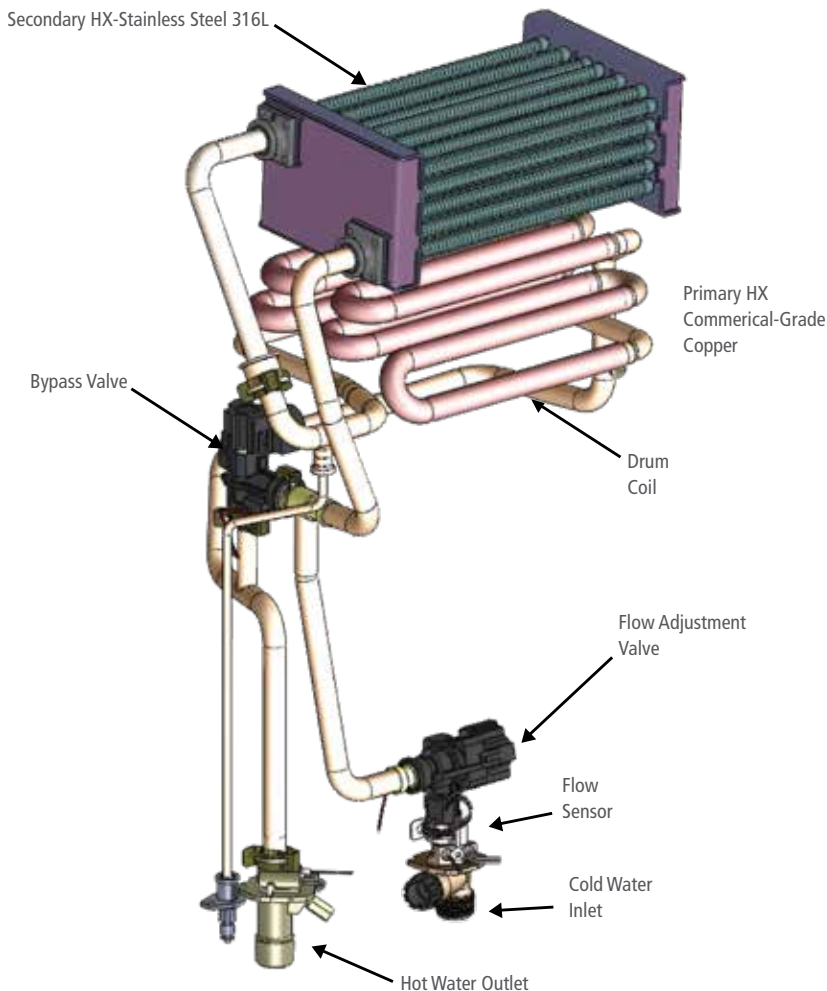

A thinner drum strains more under heat stress

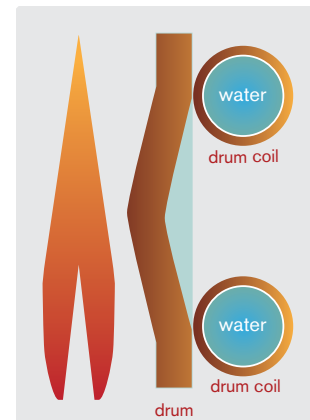

A thicker drum creates less strain on the heat exchanger

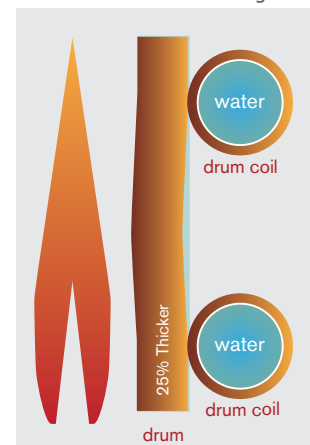

VALVES AND WATER FLOW

Making true commercial-grade water heaters involves more than just redesigning our heat exchangers—every internal component has to measure up to A. O. Smith’s commercial standards. Just like our advanced heat exchangers, the longevity and functionality of components such as our water valves and flow sensors are also of great importance.

Our commercial-grade water heaters (510U/C, 540 and 540P/X3), as well as our commercial water heaters (CT-199 and 910) feature a bypass and flow adjustment valve, which not only provide the optimal control and precision essential for commercial usage, but also offer the durability needed to handle tough, high-volume conditions.



Stepper Motor Water Valves - 910 Models



Bypass Valve - 510U/C,
CT-199 and 540H Models



Flow Adjustment - 510U/C,
CT-199 and 540H Models

Water Flow

Condensation can build up over time in any heat exchanger, causing damage and premature leaks. A. O. Smith’s commercial models (910 series) include condensation reduction features that safeguard against these types of damaging effects.

Better Water Pathway Design

By redesigning and redirecting the flow of water, the temperature of the heat exchanger drum and finned coils stay elevated above dew point, making it much more difficult for condensation to build.

Fin Pitch

By widening the pitch of the heat exchanger fins, not only do we improve durability by reducing occurrences of blockage, we also maintain higher temperatures on the upper finned coils. Keeping these coils at elevated temperatures reduces the likelihood of condensation buildup.



FIN

RESIDENTIAL CONDENSING WITH X3® SCALE PREVENTION TECHNOLOGY



Features

No annual descaling required

No scale buildup means the heater maintains like-new performance longer

3" venting up to 70 equivalent feet

Recirc Capable

- Tankless water heaters with X3 Technology are approved to work with an external recirculation pump and cross-over valve. See manual for full details.

Warranty

- No hardwater exclusions in the industry's first "peace of mind" limited warranty
- 15-year limited warranty on heat exchanger in residential applications
- 5-year limited warranty on all parts in residential applications
- 1-year limited warranty on heat exchanger and parts in commercial applications
- Refer to hotwater.com for further warranty details

Specifications

Model Number*	Type	Gas Consumption Input**		Inlet Gas Pressure**		UEF
		Minimum (BTU/H)	Maximum (BTU/H)	Minimum (in. W.C.)	Maximum (in. W.C.)	
ATI-540HX3-N	Natural	15,000	199,000	4.0	10.5	0.93
ATO-540HX3-N+	Natural	15,000	199,000	4.0	10.5	0.95
ATI-340HX3-N+	Natural	15,000	180,000	4.0	10.5	0.95
ATO-340HX3-N	Natural	15,000	180,000	4.0	10.5	0.94
ATI-240HX3-N	Natural	15,000	160,000	4.0	10.5	0.94
ATO-240HX3-N+	Natural	15,000	160,000	4.0	10.5	0.95

Model Number*	Maximum GPM	Hot/Cold Connections	Gas Connection	Approx Shipping Weight (lbs)
ATI-540HX3-N	10	3/4" NPT	3/4" NPT	73
ATO-540HX3-N	10	3/4" NPT	3/4" NPT	73
ATI-340HX3-N	8	3/4" NPT	3/4" NPT	72
ATO-340HX3-N	8	3/4" NPT	3/4" NPT	71
ATI-240HX3-N	6.6	3/4" NPT	3/4" NPT	72
ATO-240HX3-N	6.6	3/4" NPT	3/4" NPT	71

*For propane models, change "N" to "P"

**For propane models, minimum fire is 13,000 BTU/H, minimum inlet gas pressure is 8.0 in. W.C. and maximum inlet gas pressure is 14.0 in. W.C.

+ENERGY STAR® Qualified

Temperature Settings	120°F (Default Setting)		
	100-140°F (5°F Increments)		
Electric	120 V	60 Hz	1.63 Amps



Select models

ANSI Z21.10.3 • CSA 4.3

Dimensions

Model Number	Clearances (inches)			
	Top	Bottom	Side	Front
ATI-540HX3-N	12	12	3	4
ATO-540HX3-N	36	12	3	24
ATI-340HX3-N	12	12	3	4
ATO-340HX3-N	36	12	3	24
ATI-240HX3-N	12	12	3	4
ATO-240HX3-N	36	12	3	24

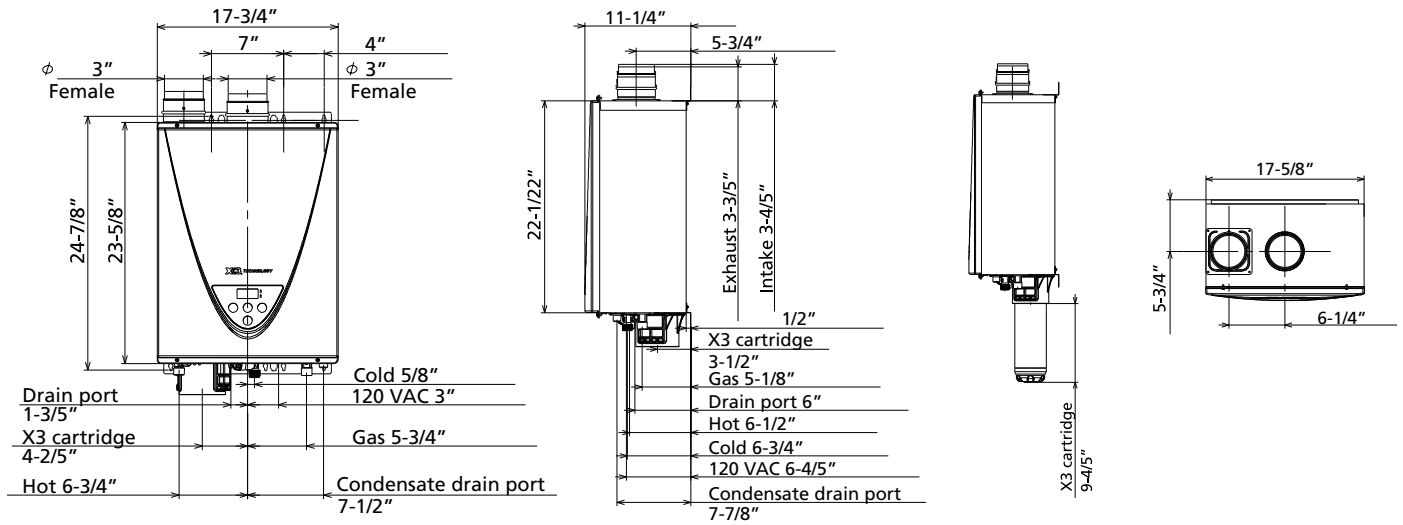

Accessories



**Recess Box
Retrofit:**
(100298009)
New Construction:
(100306285)



Pipe Cover
(100112718)



**Remote
Temperature
Controller**
(100276687)

RESIDENTIAL CONDENSING WITH X3[®] SCALE PREVENTION TECHNOLOGY

540HX3 Output Temp vs. GPM

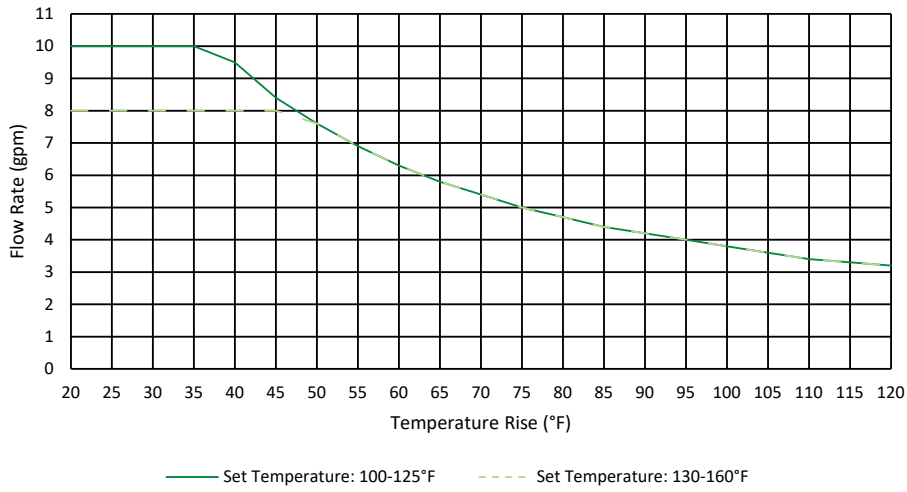

340HX3 Output Temp vs. GPM

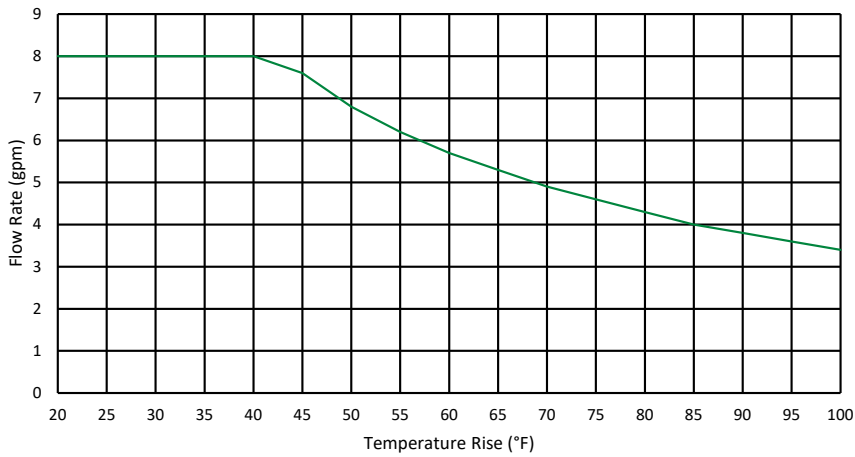

240HX3 Output Temp vs. GPM

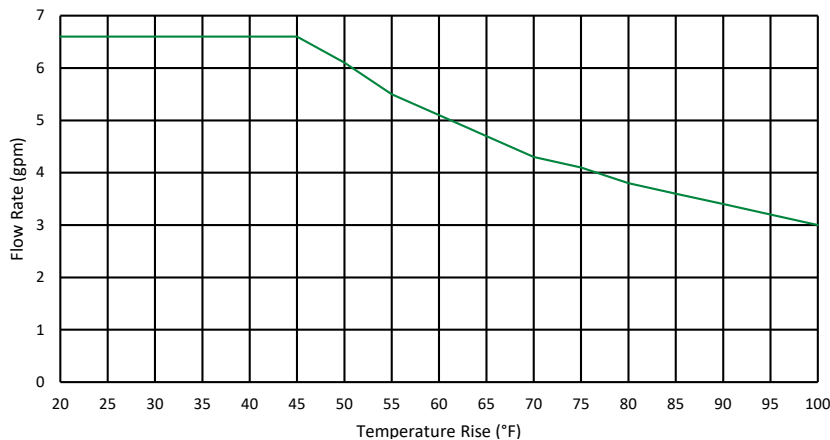

540HX3 Pressure Loss

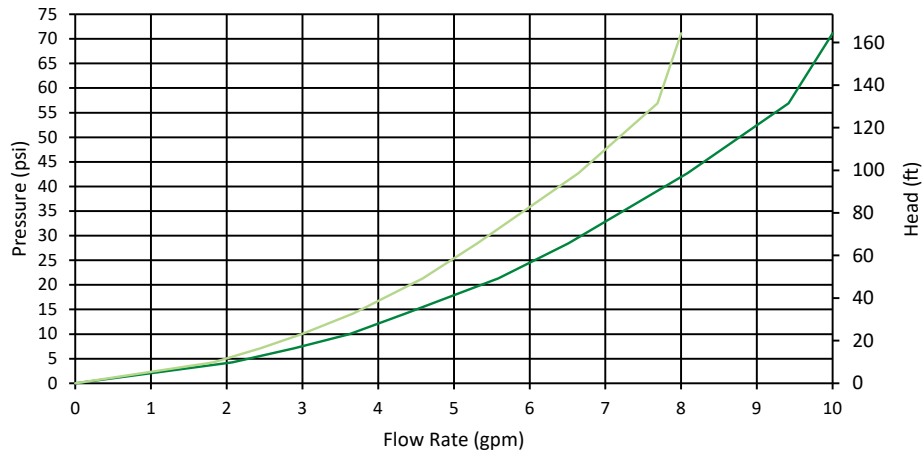

— Set Temp: 100-125°F — Set Temp: 130-160°F
 Max flow is 8 gpm when set temp above 125

340HX3 Pressure Loss

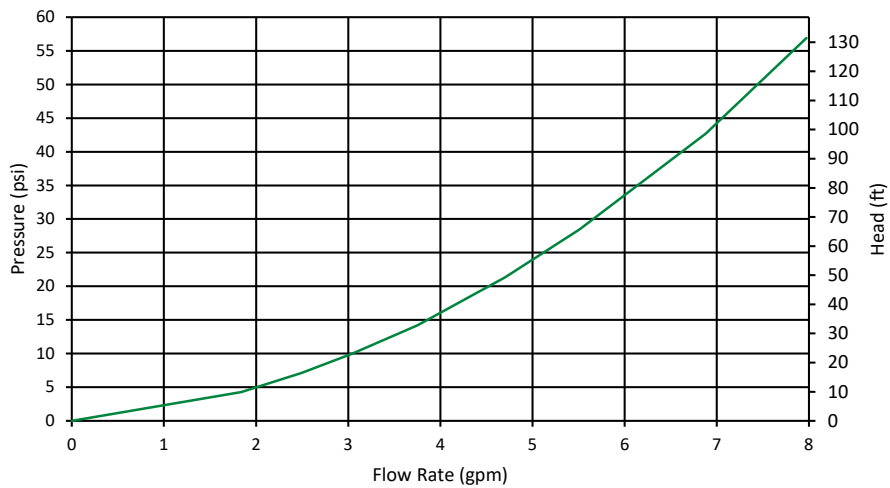

240HX3 Pressure Loss

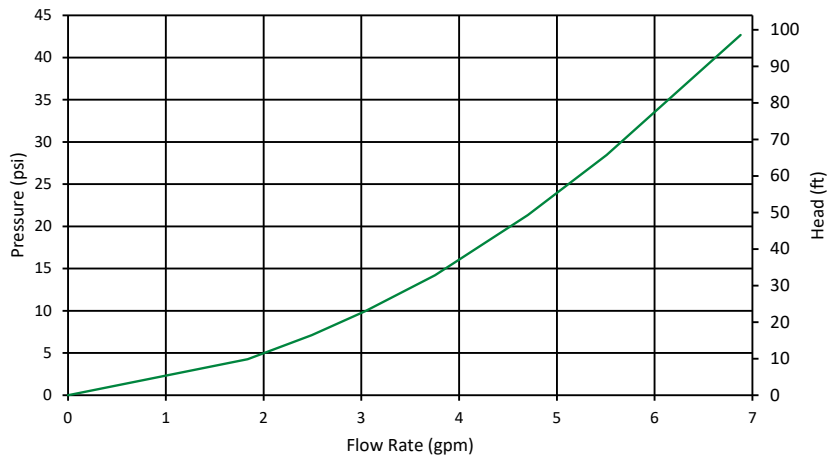

RESIDENTIAL CONDENSING WITH INTEGRATED RECIRCULATION PUMP



Features

Integrated recirculation pump for instant hot water

EASY-LINK™ with up to 3 other 540H heaters

3" venting up to 70 equivalent feet

Warranty

- 15-year limited warranty on heat exchanger in residential applications
- 5-year limited warranty on heat exchanger in commercial applications
- 5-year warranty on all parts
- Refer to hotwater.com for further warranty details

Specifications

Model Number*	Type	Gas Consumption Input**		Inlet Gas Pressure**		UEF
		Minimum (BTU/H)	Maximum (BTU/H)	Minimum (in. W.C.)	Maximum (in. W.C.)	
ATI-540P-N	Natural	15,000	199,000	4.0	10.5	0.93
ATO-540P-N+	Natural	15,000	199,000	4.0	10.5	0.95

Model Number*	Maximum GPM	Hot/Cold Connections	Gas Connection	Approx Shipping Weight (lbs)
ATI-540P-N	10	3/4" NPT	3/4" NPT	71
ATO-540P-N	10	3/4" NPT	3/4" NPT	69

*For propane models, change "N" to "P"

**For propane models, minimum fire is 13,000 BTU/H, minimum inlet gas pressure is 8.0 in. W.C. and maximum inlet gas pressure is 14.0 in. W.C.

*ATO-540P-N and ATO-540P-P are ENERGY STAR® Qualified

540P Temperature Settings	120°F (Default Setting)		
	100-140°F (5°F Increments)		
Electric	120 V	60 Hz	1.63 Amps



Select models

ANSI Z21.10.3 • CSA 4.3

Dimensions

Model Number	Clearances (inches)			
	Top	Bottom	Side	Front
ATI-540P-N	12	12	3	4
ATO-540P-N	36	12	3	24

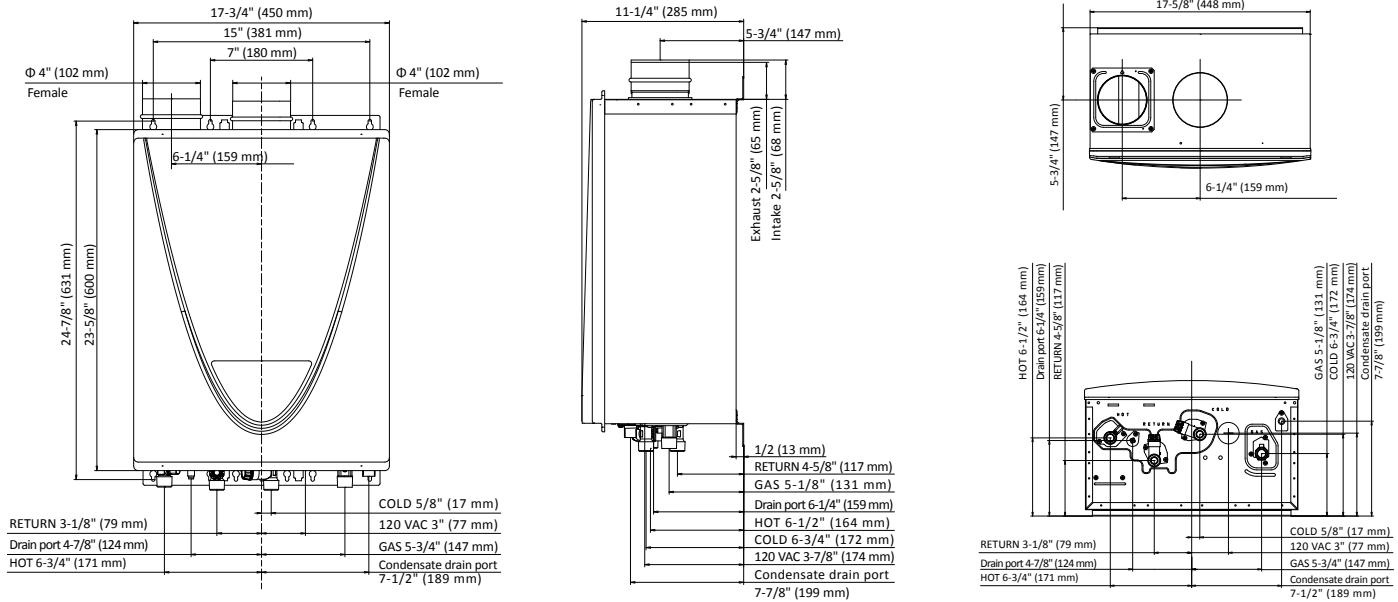

Accessories



Recess Box Retrofit:
 (100298009)
New Construction:
 (100306285)



Pipe Cover
 (100112718)



Remote Temperature Controller
 (100276687)



Isolation Valves
 (100112255)

540P Output Temp vs. GPM

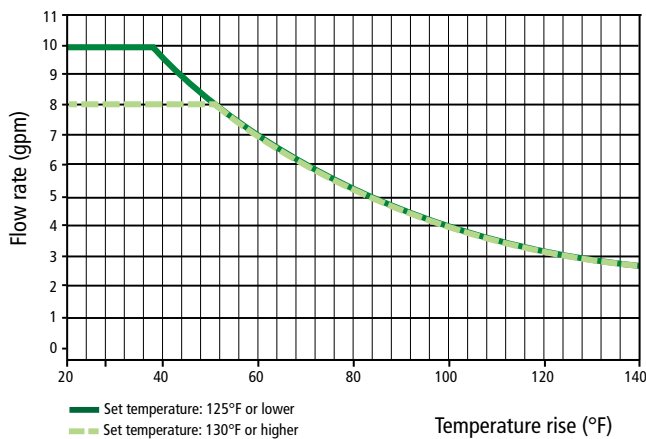

540P Pressure Loss

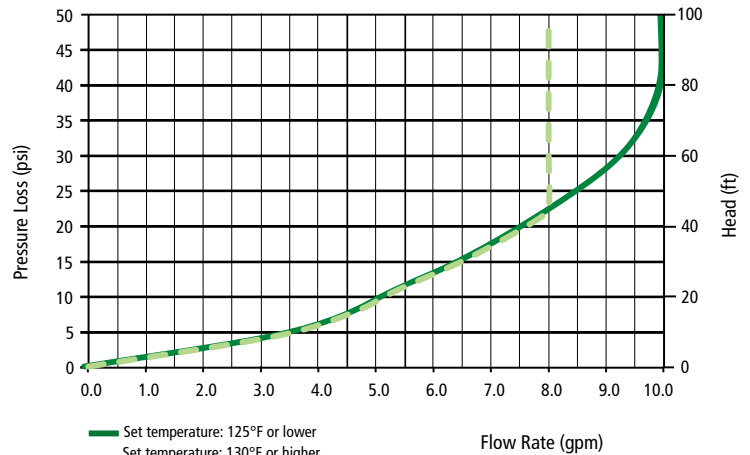

RESIDENTIAL CONDENSING



Features

Continuous maximum flow rates up to 10.0 GPM

Ultra-Low NOx gas tankless water heaters

540 models can be used in residential and commercial applications

EASY-LINK™ up to four 540H heaters or up to twenty 540H heaters with multi-unit controller

Warranty

- 15-year limited warranty on heat exchanger in residential applications
- 5-year limited warranty on heat exchanger in commercial applications
- 5-year warranty on all parts
- Refer to hotwater.com for further warranty details

Specifications

Model Number*	Type	Gas Consumption Input**		Inlet Gas Pressure**		UEF
		Minimum (BTU/H)	Maximum (BTU/H)	Minimum (in. W.C.)	Maximum (in. W.C.)	
ATI-540H-N	Natural	15,000	199,000	4.0	10.5	0.93
ATO-540H-N+	Natural	15,000	199,000	4.0	10.5	0.95
ATI-340H-N+	Natural	15,000	180,000	4.0	10.5	0.95
ATO-340H-N	Natural	15,000	180,000	4.0	10.5	0.94
ATI-240H-N	Natural	15,000	160,000	4.0	10.5	0.94
ATO-240H-N+	Natural	15,000	160,000	4.0	10.5	0.95

Model Number*	Maximum GPM	Hot/Cold Connections	Gas Connection	Approx Shipping Weight (lbs)
ATI-540H-N	10	3/4" NPT	3/4" NPT	71
ATO-540H-N	10	3/4" NPT	3/4" NPT	69
ATI-340H-N	8	3/4" NPT	3/4" NPT	71
ATO-340H-N	8	3/4" NPT	3/4" NPT	69
ATI-240H-N	6.6	3/4" NPT	3/4" NPT	71
ATO-240H-N	6.6	3/4" NPT	3/4" NPT	69

*For propane models, change "N" to "P"

**For propane models, minimum fire rate is 13,000 BTU/H, minimum inlet gas pressure is 8.0 in. W.C. and maximum inlet gas pressure is 14.0 in. W.C.

*ENERGY STAR® Qualified.

Temperature Settings	120°F (Default Setting)		
	240H/340H: 100-140°F (5°F Increments)		
	540H: 100-160°F (5°F Increments)		
Electric	120 V	60 Hz	1.5 Amps



Select models

540H only

ANSI Z21.10.3 • CSA 4.3

Dimensions

Model Number	Clearances (inches)			
	Top	Bottom	Side	Front
ATI-540H-N	12	12	3	4
ATO-540H-N	36	12	3	24
ATI-340H-N	12	12	3	4
ATO-340H-N	36	12	3	24
ATI-240H-N	12	12	3	4
ATO-240H-N	36	12	3	24

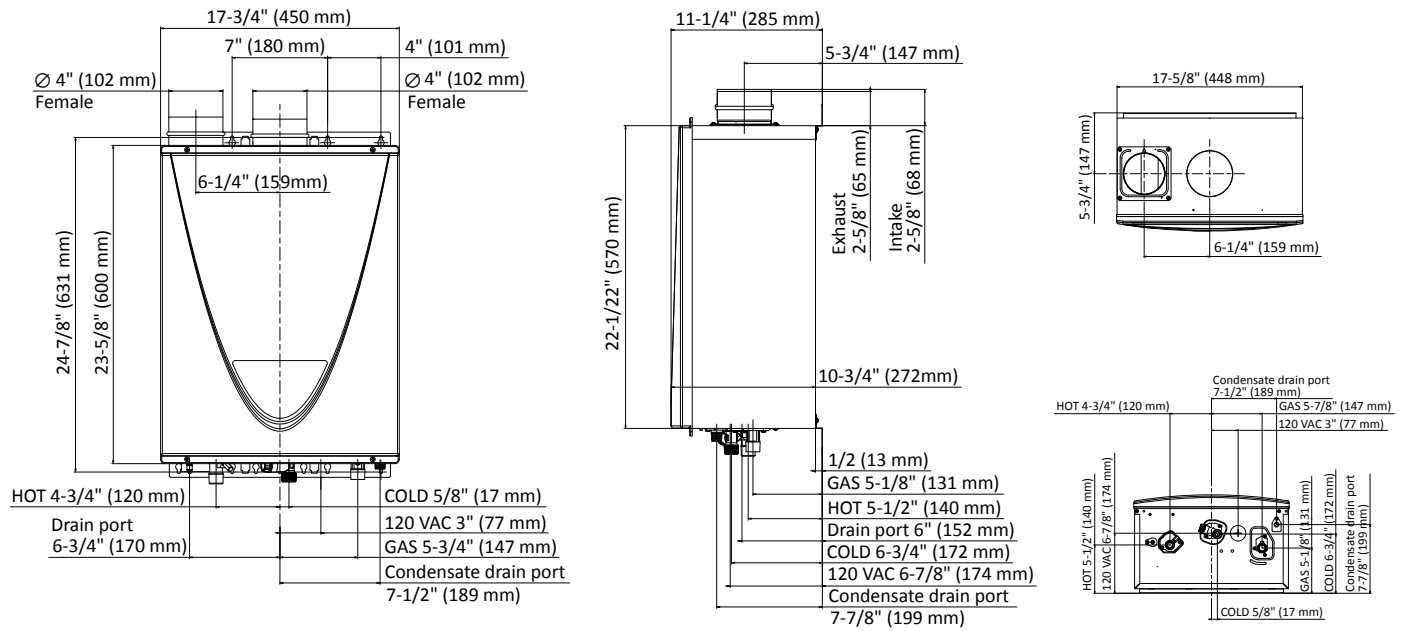

Accessories

- 

Recess Box
Retrofit: (100298009)
New Construction: (100306285)
- 

Pipe Cover
(100112718)
- 

Remote Temperature Controller
(100209924)
- 

Multi-Unit Controller*
(100112691)
*Only available for 540H
- 3" Concentric Termination**
(100112163)
- 

Isolation Valves
(100112255)

RESIDENTIAL CONDENSING

540H Output Temp vs. GPM

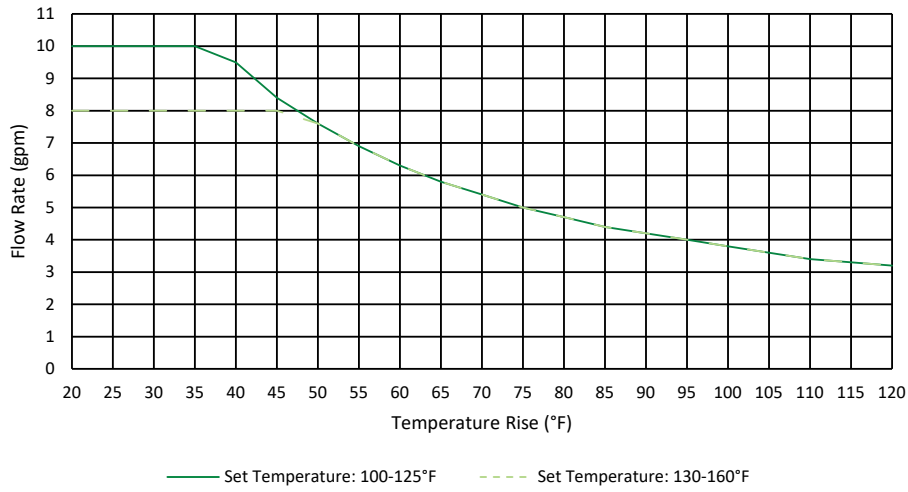

340H Output Temp vs. GPM

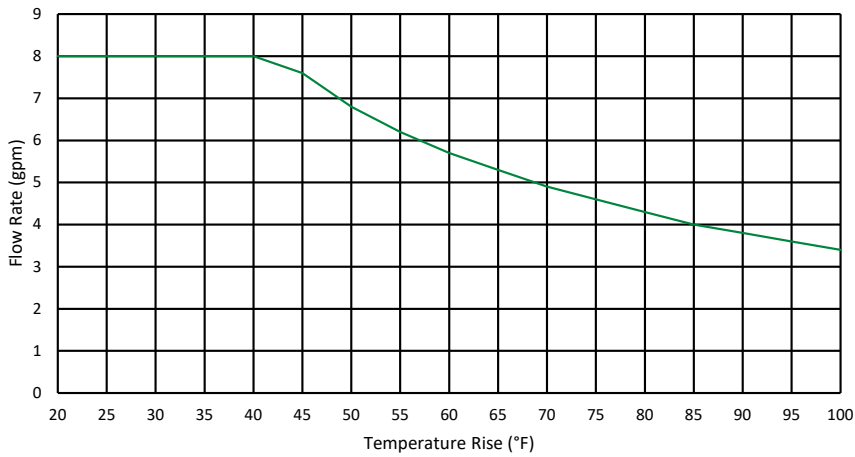

240H Output Temp vs. GPM

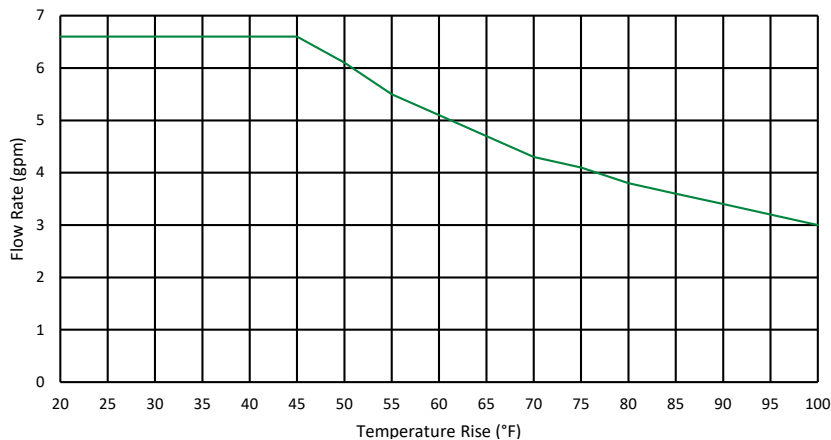

540H Pressure Loss

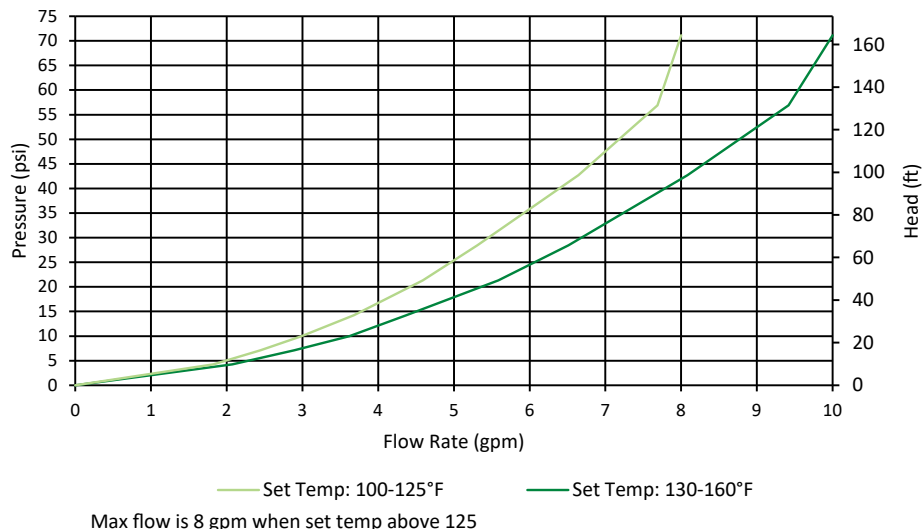

340H Pressure Loss

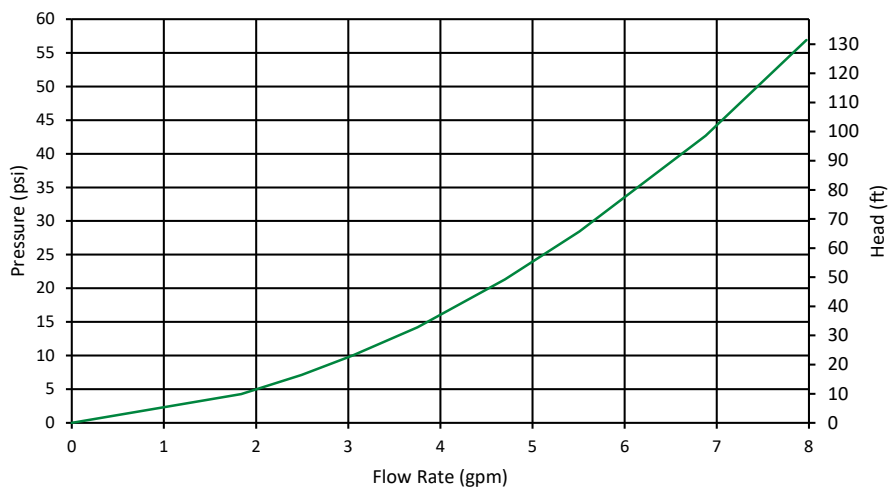

240H Pressure Loss

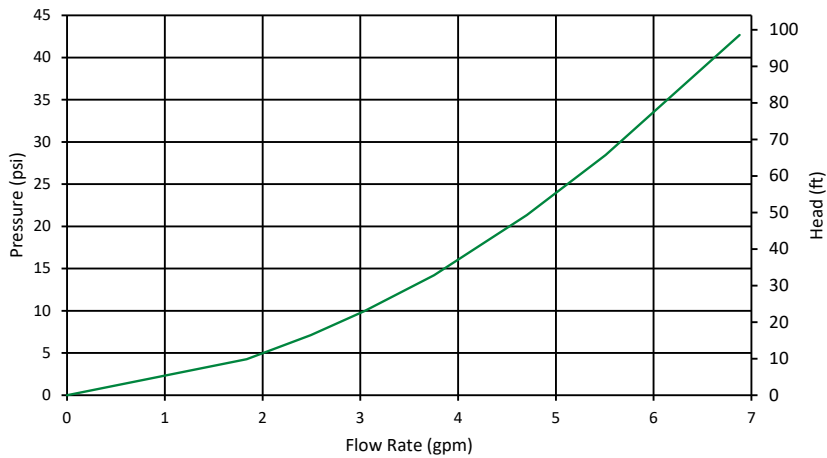

RESIDENTIAL CONDENSING



Features

Operates with 1/2" gas line

Designed to fit between standard framing construction

3" venting up to 70 equivalent feet

Warranty

- 15-year limited warranty on heat exchanger in residential applications
- 5-year limited warranty on heat exchanger in commercial applications
- 5-year warranty on all parts
- Refer to hotwater.com for further warranty details

Specifications

Model Number*	Type	Gas Consumption Input		Inlet Gas Pressure**		UEF
		Minimum (BTU/H)	Maximum (BTU/H)	Minimum (in. W.C.)	Maximum (in. W.C.)	
ATI-140H-N	Natural	15,000	120,000	4.0	10.5	0.90
ATO-140H-N	Natural	15,000	120,000	4.0	10.5	0.91

Model Number*	Maximum GPM	Hot/Cold Connections	Gas Connection	Approx Shipping Weight (lbs)
ATI-140H-N	6.6	3/4" NPT	1/2" NPT	54
ATO-140H-N	6.6	3/4" NPT	1/2" NPT	52

*For propane models, change "N" to "P"

**For propane models, minimum fire is 13,000 BTU/H, minimum inlet gas pressure is 8.0 in. W.C. and maximum inlet gas pressure is 14.0 in. W.C.

140H Temperature Settings	120°F (Default Setting)		
	100-140°F (5°F Increments)		
Electric	120 V	60 Hz	1.94 Amps



ANSI Z21.10.3 • CSA 4.3

Dimensions

Model Number	Clearances (inches)			
	Top	Bottom	Side	Front
ATI-140H-N	12	12	3	4
ATO-140H-N	36	12	3	24

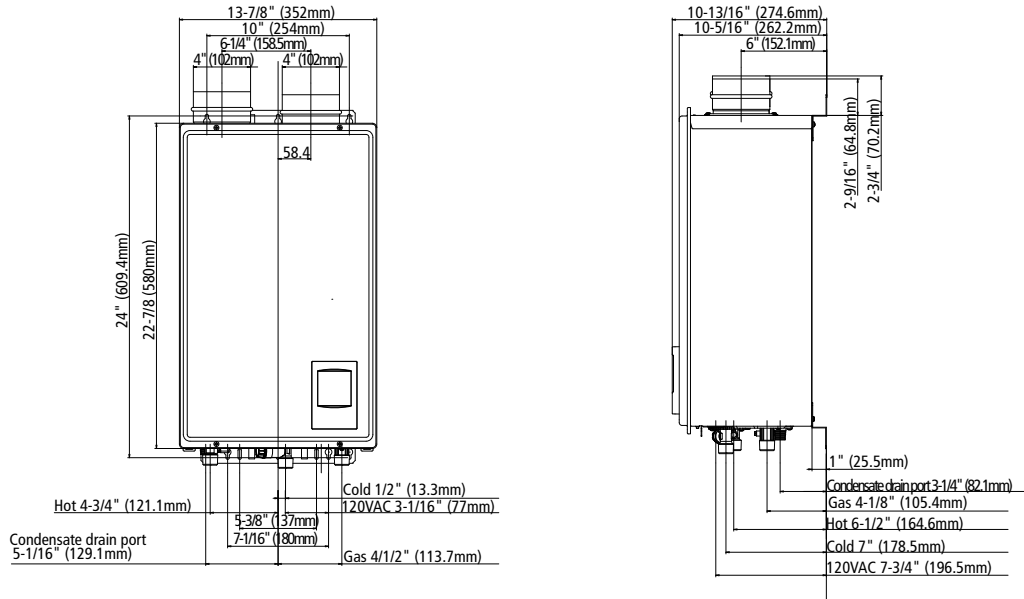

Accessories



Recess Box Std Retrofit
(100266729)
Recess Box Flange
(100266730)



Pipe Cover
(100187904)



Remote Temperature Controller
(100209924)



3" Concentric Termination
(100112163)



Isolation Valves
(100112255)

140H Output Temp vs. GPM

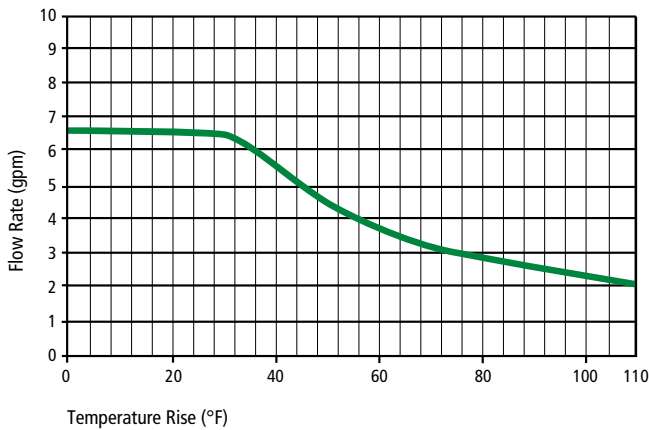

140H Pressure Loss

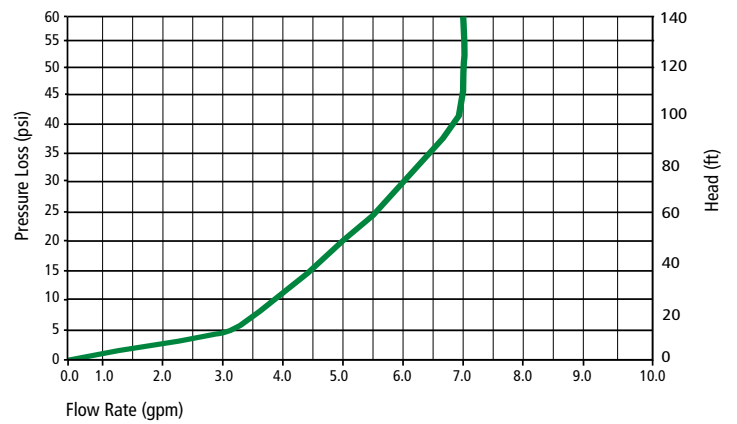

RESIDENTIAL NON-CONDENSING ULTRA-LOW NOX



Features

Gas convertible from natural gas to propane using the included conversion kit

4" category III vent up to 60 equivalent feet

EASY-LINK™ up to four 510U heaters or up to twenty 510U heaters with multi-unit controller

Warranty

- 15-year limited warranty on heat exchanger in residential applications
- 5-year limited warranty on heat exchanger in commercial applications
- 5-year warranty on all parts
- Refer to hotwater.com for further warranty details

Specifications

Model Number*	Type	Gas Consumption Input		Inlet Gas Pressure**		UEF
		Minimum (BTU/H)	Maximum (BTU/H)	Minimum (in. W.C.)	Maximum (in. W.C.)	
ATI-510U	Natural	15,000	199,000	4.0	10.5	0.81
ATO-510U	Natural	15,000	199,000	4.0	10.5	0.81
ATI-310U	Natural	15,000	199,000	4.0	10.5	0.81
ATO-310U	Natural	15,000	199,000	4.0	10.5	0.81
ATI-110U	Natural	15,000	140,000	4.0	10.5	0.81
ATO-110U	Natural	15,000	140,000	4.0	10.5	0.81

Model Number*	Maximum GPM	Hot/Cold Connections	Gas Connection	Approx Shipping Weight (lbs)
ATI-510U	10	3/4" NPT	3/4" NPT	40
ATO-510U	10	3/4" NPT	3/4" NPT	40
ATI-310U	8	3/4" NPT	3/4" NPT	39
ATO-310U	8	3/4" NPT	3/4" NPT	39
ATI-110U	6.6	3/4" NPT	3/4" NPT	39
ATO-110U	6.6	3/4" NPT	3/4" NPT	39

*Units are field convertible from natural gas to propane with supplied conversion kit.

**For propane, minimum inlet gas pressure is 8.0 in. W.C. and maximum inlet gas pressure is 14.0 in. W.C.

Temperature Settings	120°F (Default Setting)		
	110U/310U: 100-140°F (5°F Increments)		
	510U: 100-160°F (5°F Increments)		
Electric	120 V	60 Hz	1.02 Amps



ANSI Z21.10.3 • CSA 4.3

Dimensions

Model Number	Clearances (inches)			
	Top	Bottom	Side	Front
ATI-510U	12	12	3	4
ATO-510U	36	12	3	24
ATI-310U	12	12	3	4
ATO-310U	36	12	3	24
ATI-110U	12	12	3	4
ATO-110U	36	12	3	24

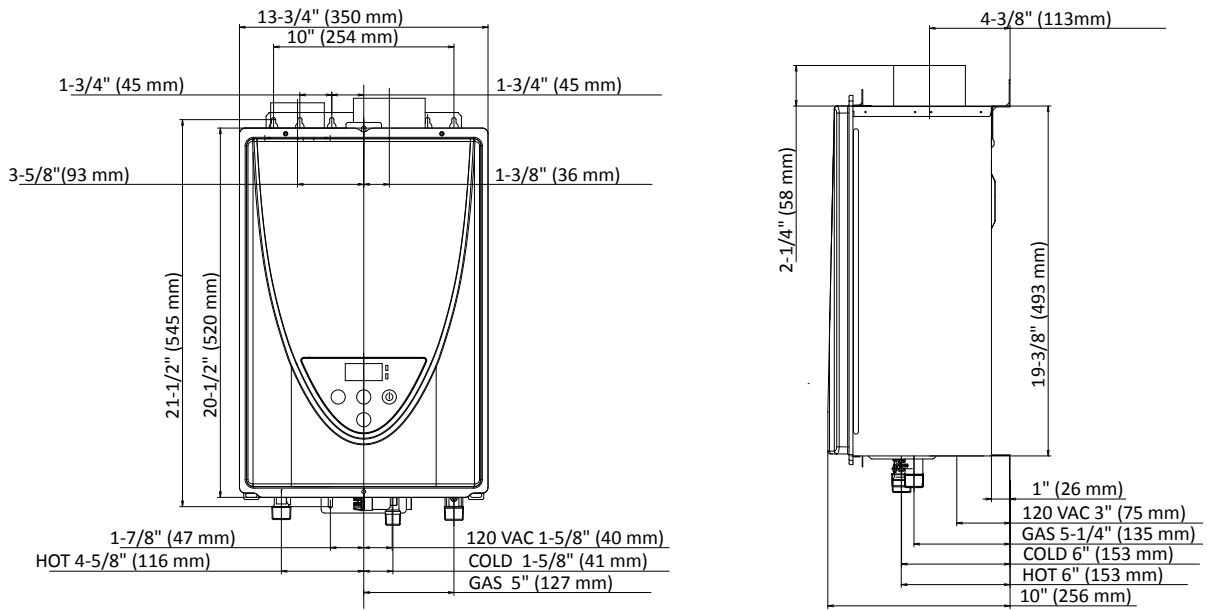

Accessories



Recess Box Std Retrofit
(100266729)
Recess Box Flange
(100266730)



Pipe Cover
(100324434)



Remote Temperature Controller
(100209924)



Multi-Unit Controller*
(100112691)
*Only available for 510U



Isolation Valves
(100112255)

RESIDENTIAL NON-CONDENSING ULTRA-LOW NOX

510U Output Temp vs. GPM

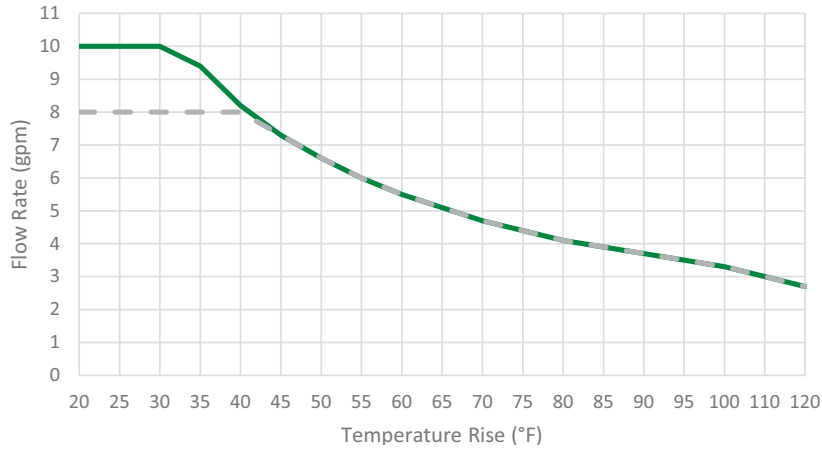

310U Output Temp vs. GPM

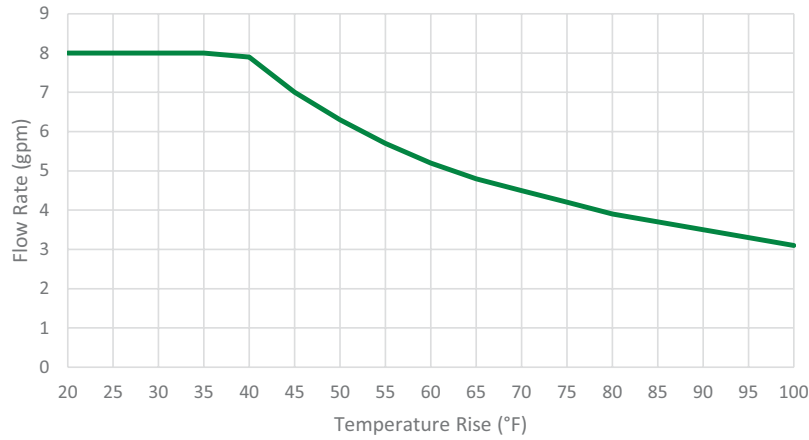

110U Output Temp vs. GPM

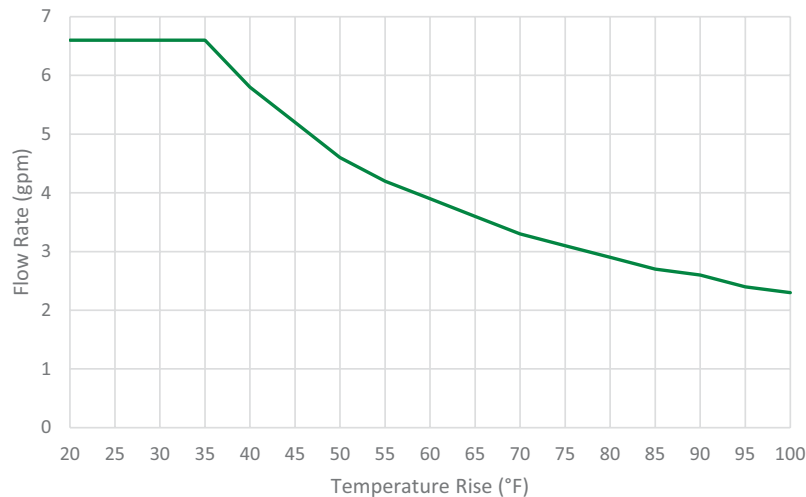

510U Pressure Loss

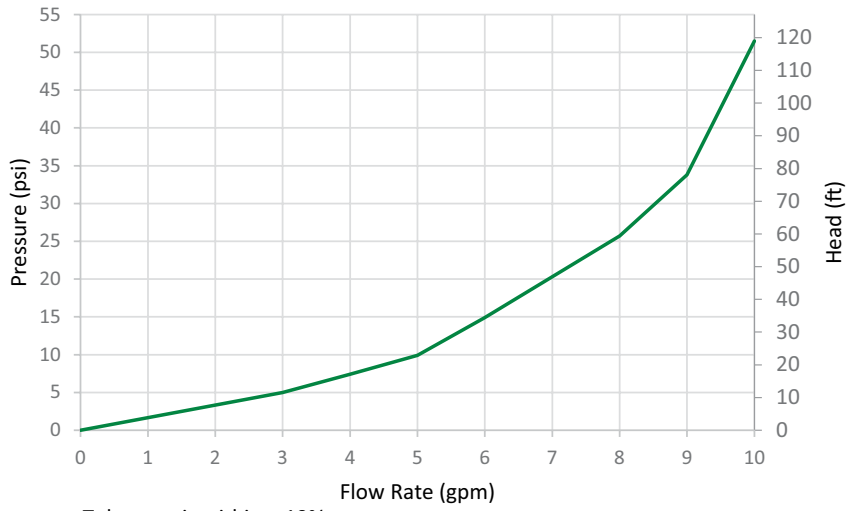

310U Pressure Loss

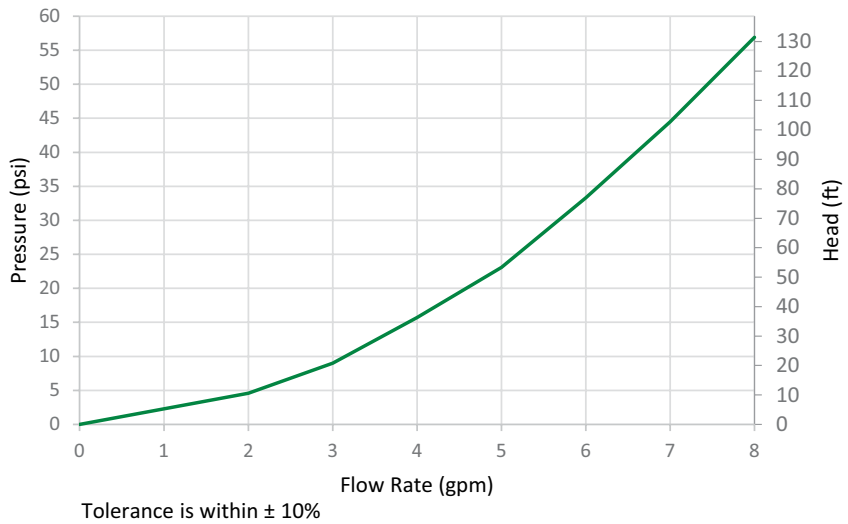

110U Pressure Loss

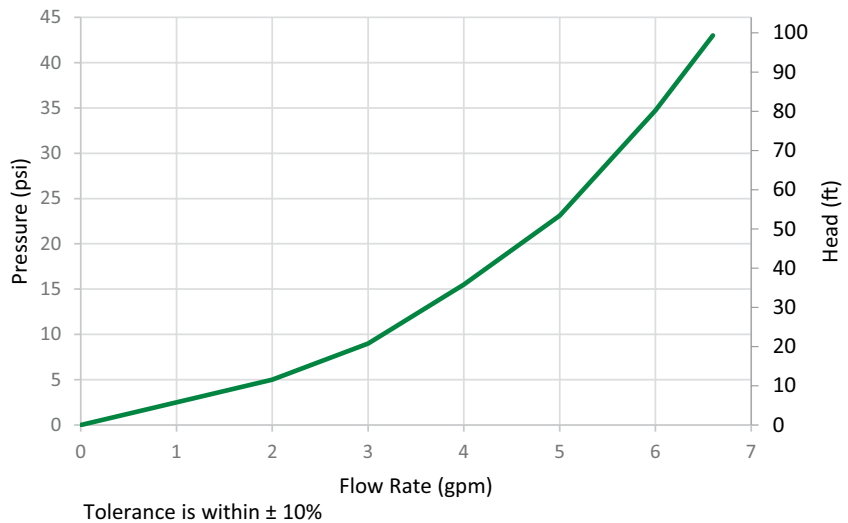

RESIDENTIAL NON-CONDENSING CONCENTRIC VENT



Features

Installations are simple and flexible with contractor preferred concentric venting

Venting runs up to 43 equivalent feet

Gas convertible from natural gas to propane using the included conversion kit

Easy-Link™ up to four 510C heaters or up to twenty 510C heaters with multi-unit controller

Warranty

- 15-year limited warranty on heat exchanger in residential applications
- 5-year limited warranty on heat exchanger in commercial applications
- 5-year warranty on all parts
- Refer to hotwater.com for further warranty details

Specifications

Model Number*	Type	Gas Consumption Input		Inlet Gas Pressure**		UEF
		Minimum (BTU/H)	Maximum (BTU/H)	Minimum (in. W.C.)	Maximum (in. W.C.)	
ATI-510C-N	Natural	15,000	199,000	4.0	10.5	0.81
ATI-310C-N	Natural	15,000	199,000	4.0	10.5	0.81

Model Number*	Maximum GPM	Hot/Cold Connections	Gas Connection	Approx Shipping Weight (lbs)
ATI-510C-N	10	3/4" NPT	3/4" NPT	55
ATI-310C-N	8	3/4" NPT	3/4" NPT	55

*Indoor models only. Units are field convertible from natural gas to propane with supplied conversion kit.

**For propane, minimum inlet gas pressure is 8.0 in. W.C. and maximum inlet gas pressure is 14.0 in. W.C.

Temperature Settings	120°F (Default Setting)		
	310C: 100-140°F (5°F Increments)		
	510C: 100-160°F (5°F Increments)		
Electric	120 V	60 Hz	0.85 Amps



ANSI Z21.10.3 • CSA 4.3

Dimensions

Model Number	Clearances (inches)			
	Top	Bottom	Side	Front
ATI-510C-N	12	12	3	4
ATI-310C-N	12	12	3	4

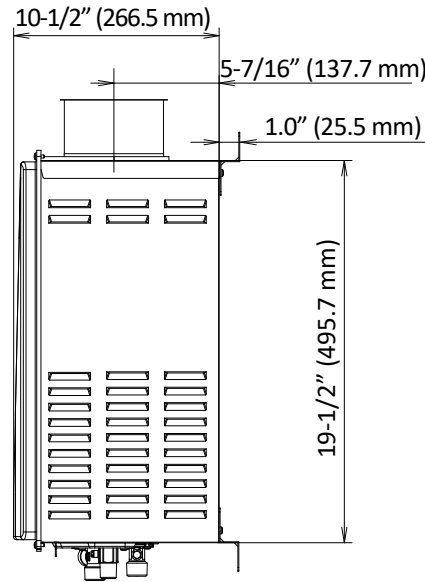
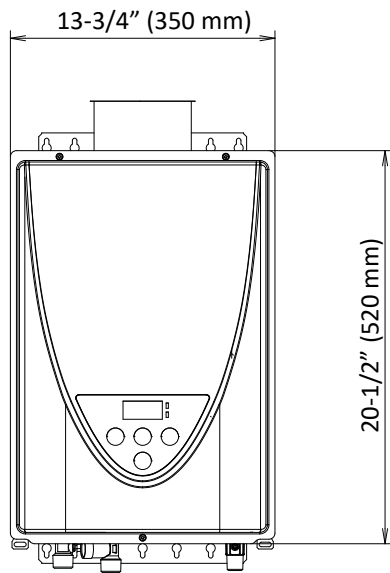

Accessories



Remote Temperature Controller (100209924)



Multi-Unit Controller* (100112691)
*Only available for 510C



Isolation Valves (100112255)

RESIDENTIAL NON-CONDENSING CONCENTRIC VENT

510C Output Temp vs. GPM

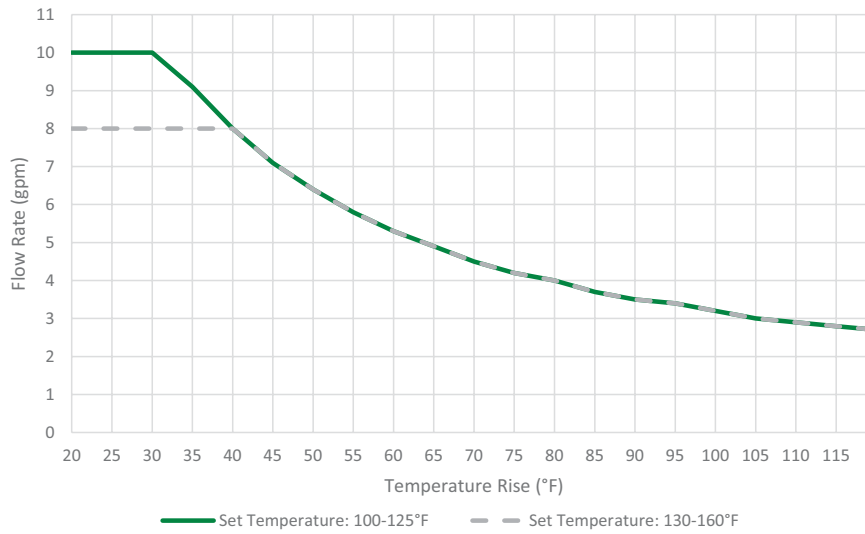

310C Output Temp vs. GPM

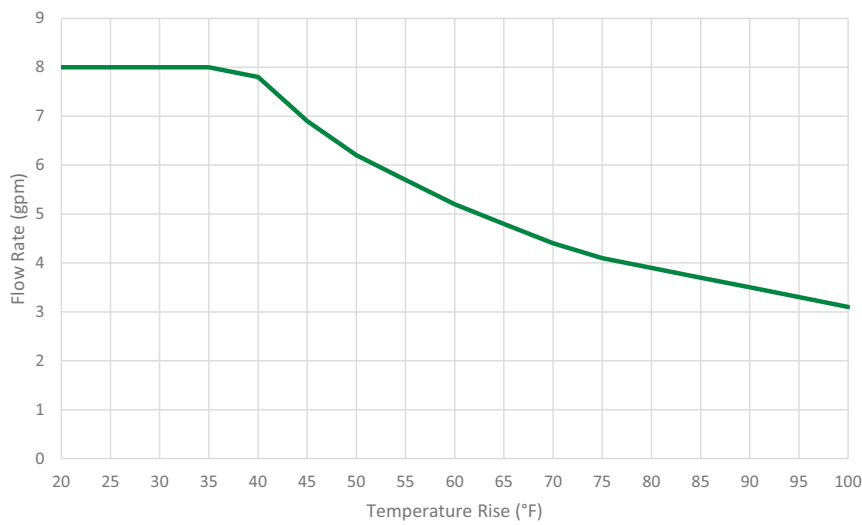

510C Pressure Loss

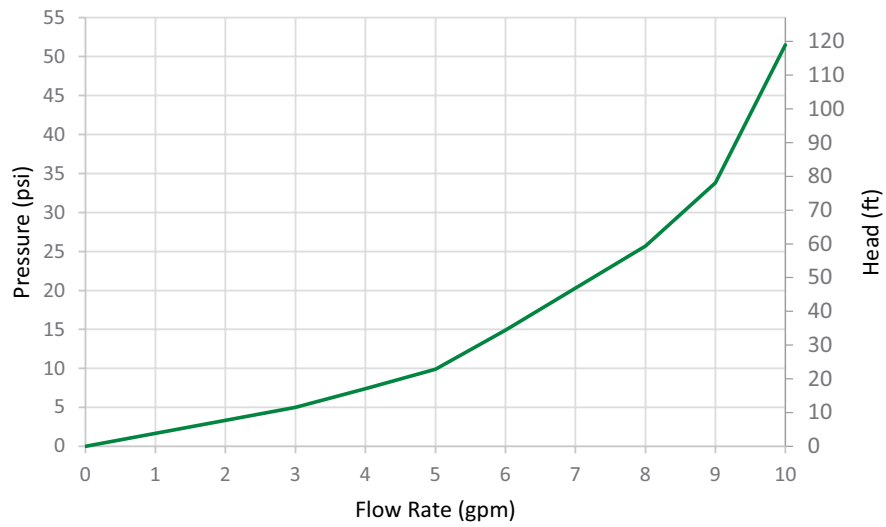

Tolerance is within $\pm 10\%$. Max flow is 8 gpm when set temp above 125 F

310C Pressure Loss

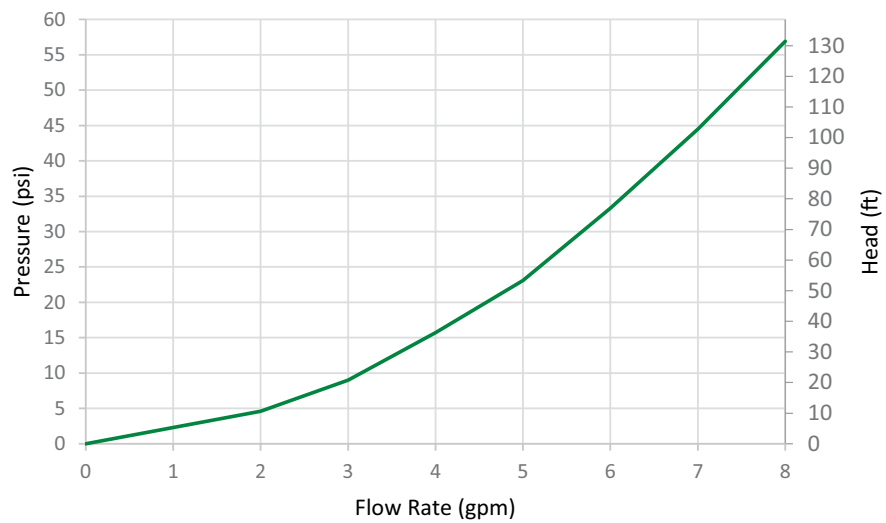

Tolerance is within $\pm 10\%$

RESIDENTIAL COMBI BOILERS

Domestic Hot Water and Space Heating How it Works:

- A hot water tap is opened causing incoming potable water to flow through the flat plate heat exchanger.
- Heated boiler water, supplied from the fire tube heat exchanger, flows through a diverter valve and into the flat plate heat exchanger where it prioritizes heating the incoming domestic water to the designated set point temperature.
- The integrated boiler pump circulates boiler water through the fire tube heat exchanger to keep it at set point temperature.
- When there is a call for space heating, the diverter valve directs the heated boiler water into the external space heating loop.

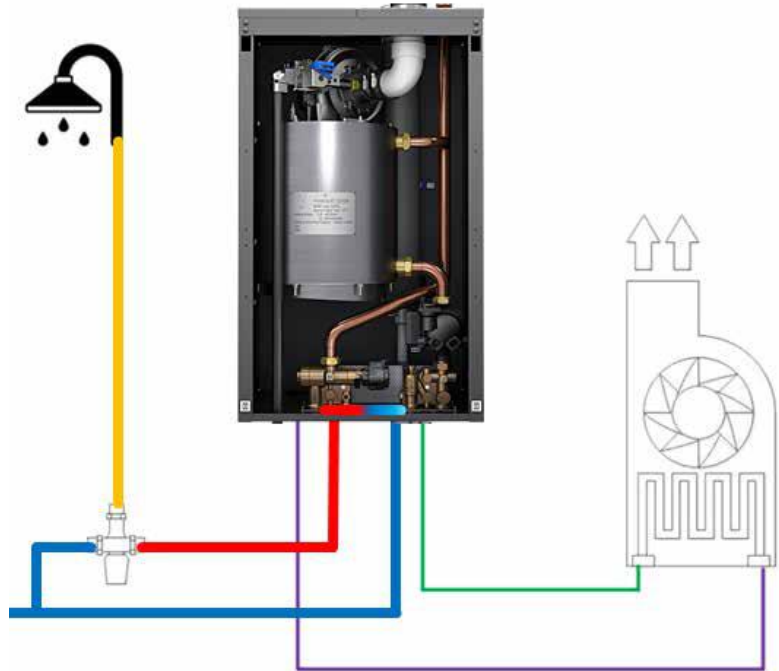

More Hot Water

ProLine® XE combi boiler provides up to 74% more heating capacity than other combi boilers. For domestic hot water (DHW), it is also sized large enough to provide 2.6 gpm (110 model) to 4.8 gpm (199 model) at a 77°F temperature rise.

Energy Conservation

With a 10:1 turndown ratio, the ProLine® XE combi boiler has the ability to modulate combustion to maximize efficiency and prevent short cycling when there are small heating demands.

Compact Size

The ProLine® XE combi boiler combines space heating and domestic hot water (DHW) in one appliance, providing a space saving choice for builders and specifying engineers.

COMBI BOILER FLOW RATE GUIDE

Temperature Rise vs. Gallons per Minute

	Temperature Rise												
	40°F	45°F	50°F	55°F	60°F	65°F	70°F	75°F	80°F	85°F	90°F	95°F	100°F
ACB-110S-N	5.1	4.5	4.0	3.7	3.4	3.1	2.9	2.7	2.5	2.4	2.2	2.1	2.0
ACB-150S-N	6.9	6.1	5.5	5.0	4.6	4.2	3.9	3.7	3.5	3.2	3.1	2.9	2.8
ACB-199S-N	9.2	8.2	7.4	6.7	6.1	5.7	5.3	4.9	4.6	4.3	4.1	3.9	3.7



Innovative Design

Fire tube heat exchanger with a higher rated MAWP of 50 psi reduces unit pressure drop. The easy access front panel can be removed without tools to simplify service.

Easy Installation and Serviceability

The LCD display is simple to navigate, providing diagnostic and system information in real words, not codes. The first time you turn on the combi boiler, you'll be lead through our Set Up Wizard for quick and easy programming.

Compact Size

The Preheat Function uses an integrated recirculation pump to ensure that the domestic hot water reaches its target temperature faster. The Air Handler Interlock prevents cool air delivery while the boiler is in domestic hot water mode to increase user comfort.

PROLINE® XE RESIDENTIAL COMBI BOILER



Features

Indoor installation only

Modulating burner with 10:1 turndown ratio

DHW flow rate up to 4.8 gpm at 77°F temperature rise

50 PSI max pressure (boiler); 150 PSI max pressure (DHW)

Warranty

- 10-year limited warranty on heat exchanger in residential applications
- 5-year warranty on all parts
- Refer to hotwater.com for further warranty details

Specifications

Model Number*	Gas Consumption Input		Minimum in. W.C.†	Maximum in. W.C.	AFUE%	Heating Capacity BTU/H	Net AHRI Rating BTU/H
	Minimum BTU/H	Maximum BTU/H					
ACB-110S-N	11,000	110,000	4.0	14.0	95.0	102,000	89,000
ACB-150S-N	15,000	150,000	4.0	14.0	95.0	139,000	121,000
ACB-199S-N	19,900	199,000	4.0	14.0	95.0	185,000	161,000

Model Number*	GPM at 77°F Rise	Water Connections		Gas Connection	Approx. Shipping Weight (lbs)
		Space Heating	DHW		
ACB-110S-N	2.6	1" NPT	3/4" NPT	1/2" NPT	139
ACB-150S-N	3.6	1" NPT	3/4" NPT	1/2" NPT	142
ACB-199S-N	4.8	1" NPT	3/4" NPT	1/2" NPT	159

*S Models can operate up to 4,500'. For high altitude (3,000' - 9,600'), change S to H. For liquid propane (LP), change N to P.

†For LP, minimum supply pressure is 8.0 in. W.C.

Indoor installation only.

Temperature Settings	Space Heating: 60°F – 190°F, Default 185°F		
	DHW: 60°F – 190°F, Default 150°F		
Electric	120 V	24V controls	2.2 Amps



ANSI Z21.13 • CSA 4.9

Dimensions

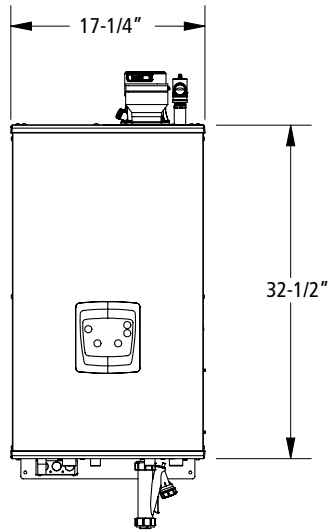

FRONT

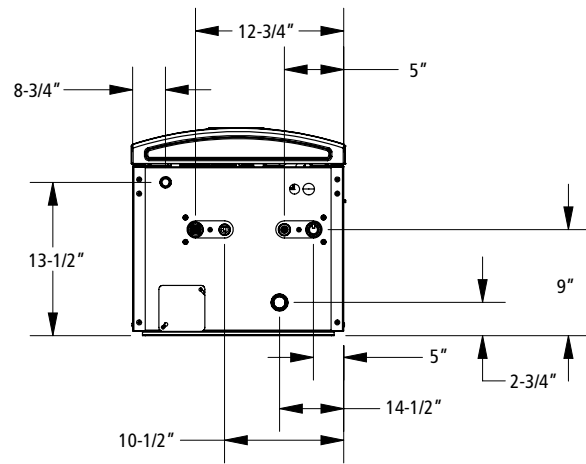

BOTTOM

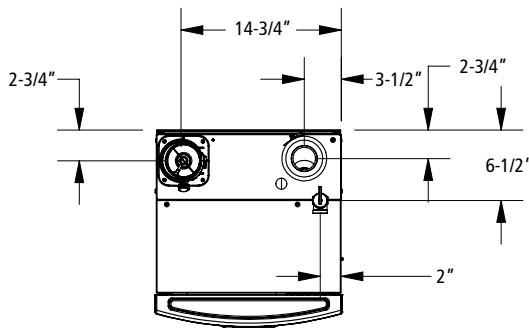

TOP
110 MODELS

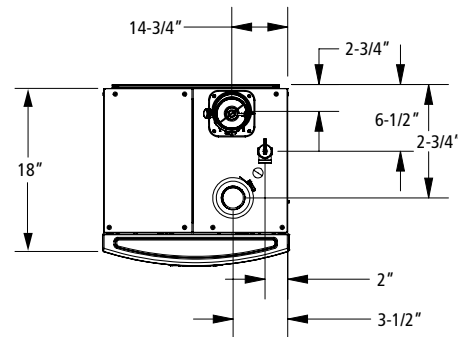

TOP
150-199 MODELS

Combi Boiler Output Temp vs. GPM

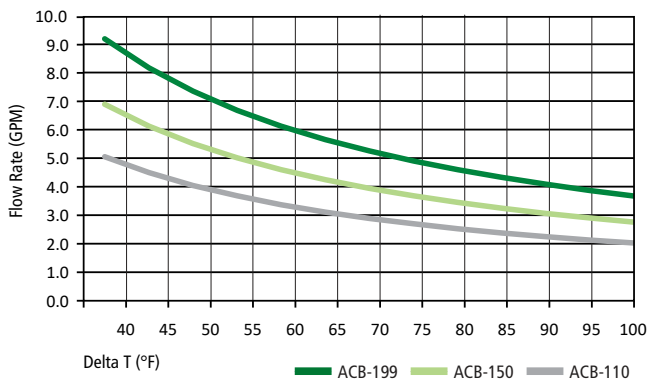

Combi Boiler Pressure Loss

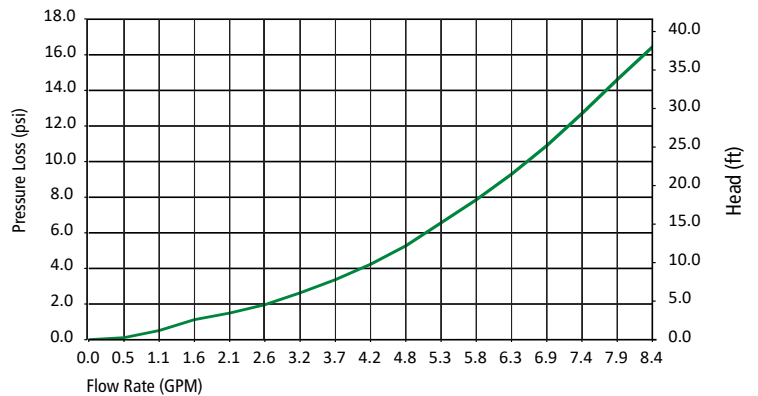

COMMERCIAL NON-CONDENSING



Features

Low NOx Emissions

EASY-LINK™ up to 4 heaters or connect up to 10 heaters with a multi-unit controller

Warranty

- 6-year limited warranty on heat exchanger in commercial applications
- 5-year warranty on all parts
- Refer to hotwater.com for further warranty details

Specifications

Model Number*	Type	Gas Consumption Input		Inlet Gas Pressure**		Thermal Efficiency
		Minimum (BTU/H)	Maximum (BTU/H)	Minimum (in. W.C.)	Maximum (in. W.C.)	
ATIO-910-N	Natural	15,000	380,000	4.0	10.5	80%

Model Number*	Type	Connections		Clearances (in.)				Approx Shipping Weight (lbs)
		Water	Gas	Top	Bottom	Side	Front	
ATIO-910-N	Natural	1" NPT	1" NPT	12***	12	2	4***	113

*For propane models, change "N" to "P"

**For propane models, minimum inlet gas pressure is 8.0 in. W.C. and maximum inlet gas pressure is 14.0 in. W.C.

***If installed outdoors, top clearance is 36" and front clearance is 24"

Temperature Settings	120°F (Default Setting)		
	No Remote: 100°F, 115°F, 135°F, 145°F, 155°F, 165°F, 185°F		
	With Remote: 100-185°F (5°F Increments)		
Electric	120 V	60 Hz	0.85 Amps



ANSI Z21.10.3 • CSA 4.3

Dimensions

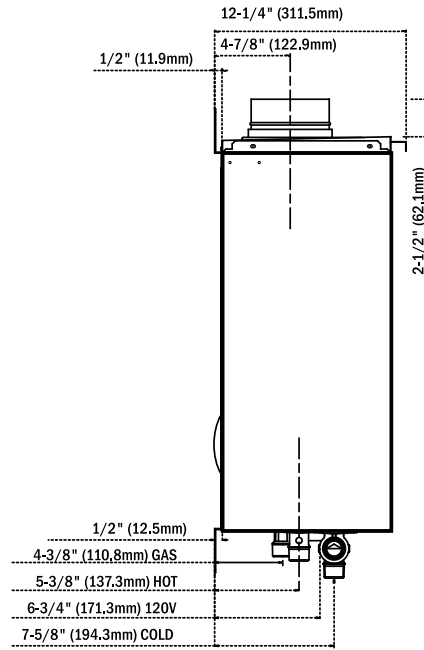
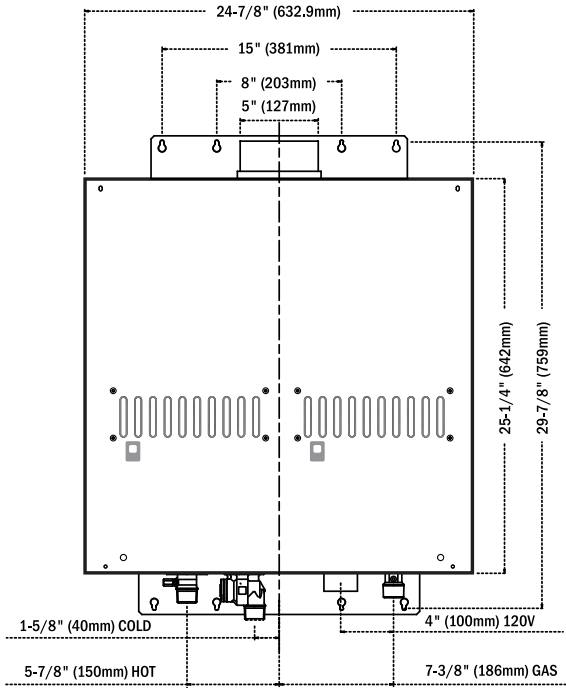

Accessories



Outdoor Vent Cap (100112194)



Pipe Cover (100112190)



Multi-Unit Controller (100112691)



Remote Temperature Controller (100112155)



Isolation Valves (100112255)



Direct Vent Conversion Kit (100112186)

910 Output Temp vs. GPM

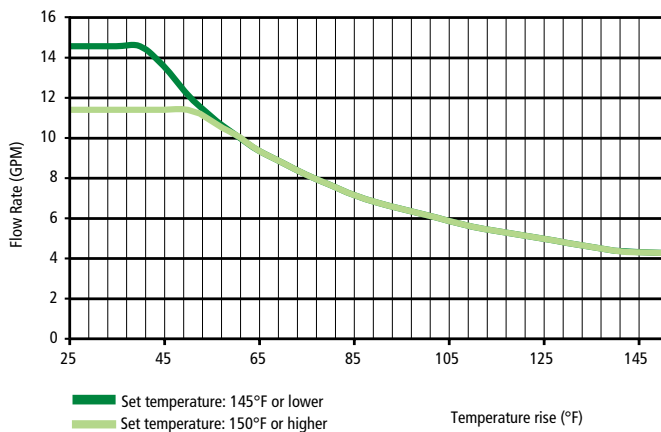

910 Pressure Loss

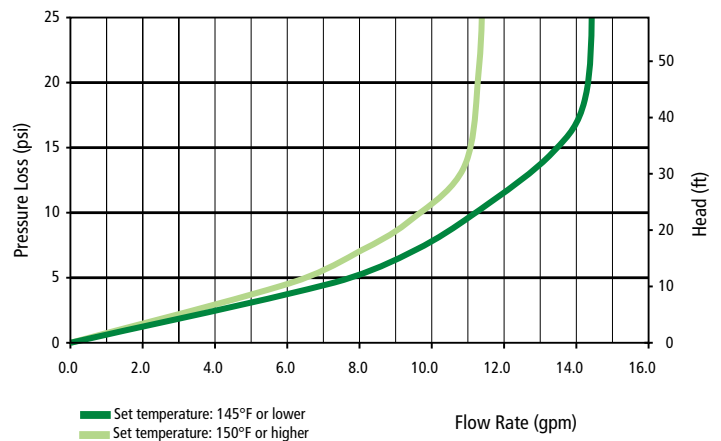

COMMERCIAL CONDENSING



Features

EASY-LINK™ up to 4 heaters or connect up to 20 heaters with a multi-unit controller

96% thermal efficiency

Warranty

- 6-year limited warranty on heat exchanger in commercial applications
- 5-year warranty on all parts
- Refer to hotwater.com for further warranty details

Specifications

Model Number*	Type	Gas Consumption Input		Inlet Gas Pressure**		Thermal Efficiency	UEF
		Minimum (BTU/H)	Maximum (BTU/H)	Minimum (in. W.C.)	Maximum (in. W.C.)		
ACT-1991-N	Natural	15,000	199,000	4.0	10.5	96%	0.93
ACT-1990-N+	Natural	15,000	199,000	4.0	10.5	96%	0.95

Model Number*	Maximum GPM	Hot/Cold Connections	Gas Connection	Approx Shipping Weight (lbs)
ACT-1991-N	10	3/4" NPT	3/4" NPT	71
ACT-1990-N	10	3/4" NPT	3/4" NPT	69

*For propane models, change "N" to "P"

**For propane models, minimum fire rate is 13,000 BTU/H, minimum inlet gas pressure is 8.0 in. W.C. and maximum inlet gas pressure is 14.0 in. W.C.

*ACT-1990-N and ACT-1990-P are ENERGY STAR® Qualified

Temperature Settings	120°F (Default Setting)		
	100-185°F (5°F Increments)		
Electric	120 V	60 Hz	1.5 Amps



Select models

ANSI Z21.10.3 • CSA 4.3

Dimensions

Model Number	Clearances (inches)			
	Top	Bottom	Side	Front
ACT-199I-N	12	12	3	4
ACT-1990-N	36	12	3	24

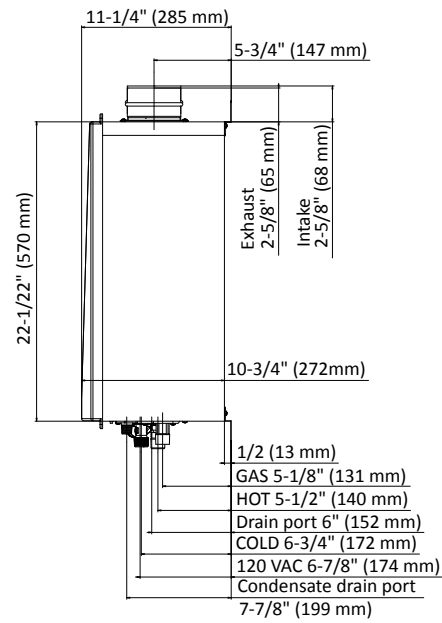
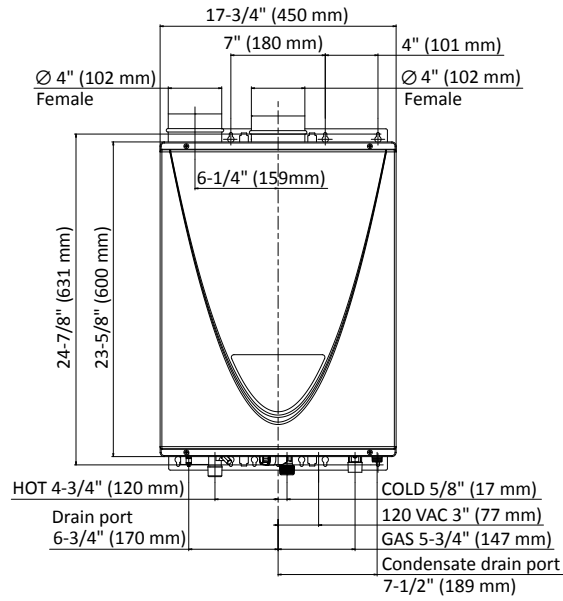

Accessories



**Recess Box
Retrofit:**
(100298009)
New Construction:
(100306285)



Pipe Cover
(100112718)



**Multi-Unit
Controller**
(100112691)



3\"/>



Isolation Valves
(100112255)

CT-199 Output Temp vs. GPM

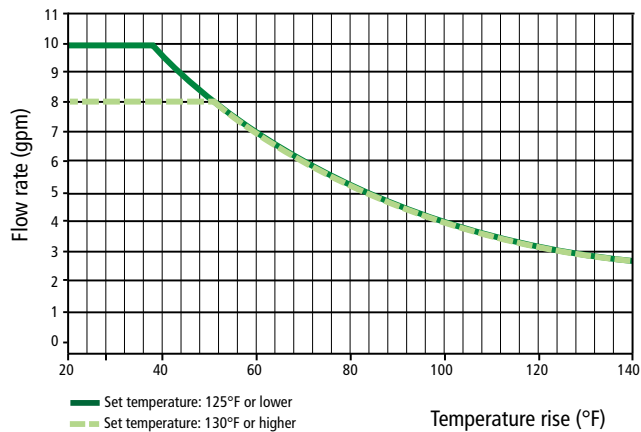

CT-199 Pressure Loss

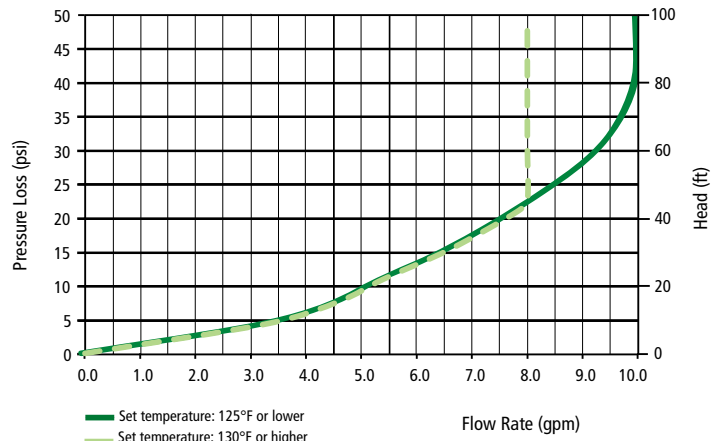

COMMERCIAL TANKLESS RACK SYSTEM

Commercial tankless rack systems allow the power of tankless technology to be customized with unprecedented flexibility. A. O. Smith offers wall mount, free standing and back-to-back configurations with easy options to integrate storage when needed. For jobs that require more than six units, custom solutions are available.

Installation is easier than ever as the rack systems are constructed from a light weight frame and just three connections for hot water, cold water and gas.

Commercial rack systems are expandable with up to 1,194,000 BTU on a single system. The rack system is designed so that individual units can be isolated for maintenance without shutting down the entire rack to provide non-stop operation.



Back-to-Back



Free Standing



Wall-Mount

MULTI-UNITS SYSTEMS

A. O. Smith tankless water heaters have the capability to link multiple heaters together to act as a system. The primary heater is rotated to ensure even operation of all heaters. The 510U/C, 540H, CT-199, and 910 models can EASY-LINK™ up to four units using included communication cables.

For even larger applications the 510U, 510C, 540H, CT-199, and 910 models also feature the Multi-Unit System, allowing a greater number of units to work together as an integrated system using a Multi-Unit System Controller. The Multi-Unit System can control up to twenty 510U, 510C, 540H, and CT-199 or up to ten 910 heaters.

Unit Comparison

	510U/C Series	540H/CT-199 Series	910 Series
EASY-LINK™ (No Controller Necessary)	Up to 4 units	Up to 4 units	Up to 4 units
Maximum input (BTU/h)	796,000	796,000	1,520,000
Multi-UNIT*	Up to 20 units	Up to 20 units	Up to 10 units
Maximum input (BTU/h)	3,980,000	3,980,000	3,800,000

*Requires Multi-Unit Controller: 100112691

Common Venting

The A. O. Smith common venting system utilizes fewer unique components so you can design your venting based on project requirements.

- More design flexibility
- Fewer wall penetrations
- Able to use schedule 40 PVC on intake and exhaust
- Heaters don't de-rate when common vented
- Design doesn't override redundancy benefits



TANKLESS APPLICATION DIAGRAMS

A. O. Smith tankless water heaters can be used in a wide variety of applications. Whether used in recirculation systems, in conjunction with storage tanks or with heating applications, our commercial units are built to provide continuous hot water when sized appropriately for your home's needs.

Local codes dictate proper compliance.

Basic Installation

(excluding 540P)

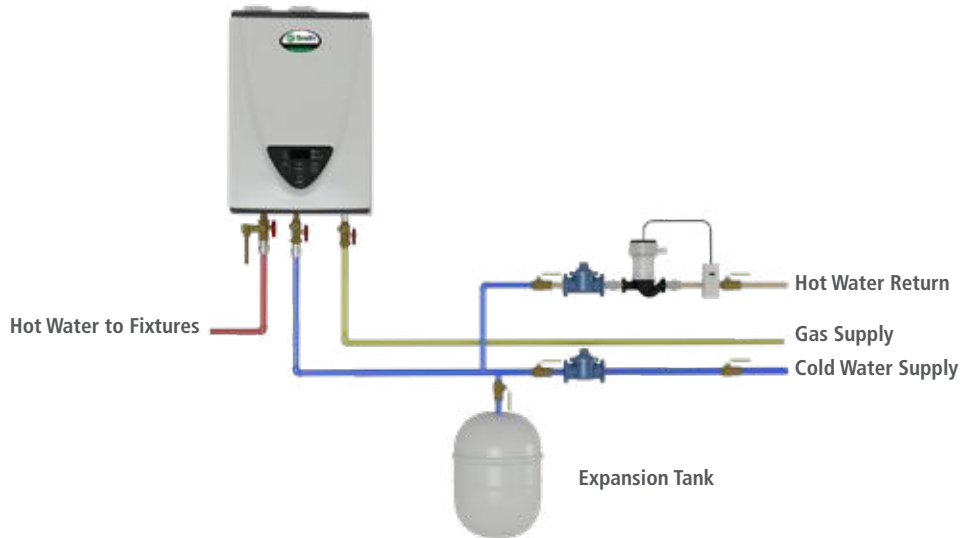

1. Recirculation pump shall be sized for 2-4 gpm per activated heater (4-8 gpm for 910)
2. Recirculation pump shall be controlled by an aquastat. The minimum suggested differential should be 10°F
3. For installations without recirculation, remove the check valves, pump, and aquastat.

540P Basic Installation

(Models with integrated recirculation only)

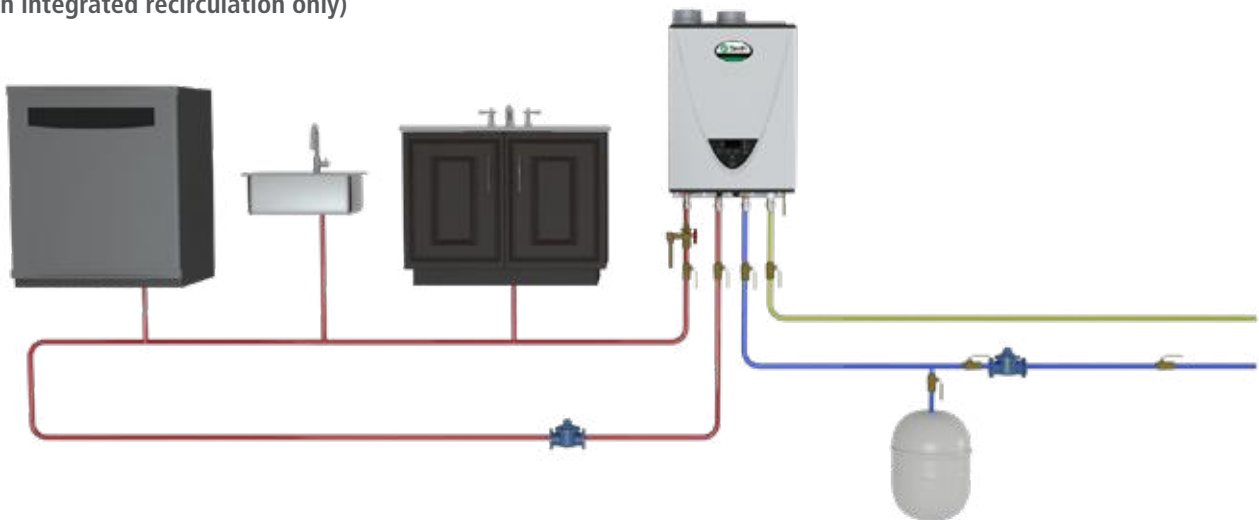

Legend



Pump



Shut Off / Isolation Valves



Pressure Relief Valve



Air Vent



Aquastat



Check Valve



Full Port Ball Valve

All application diagrams shown are concept drawings only. These diagrams are only to be used as basic guides. It is up to the application designer to properly design the plumbing layout and correctly size all components within an application (pumps, piping, storage tanks, water heaters, etc.). All national and local codes must be followed and will dictate proper compliance.

MULTIPLE UNITS

Multiple Units with EASY-LINK™

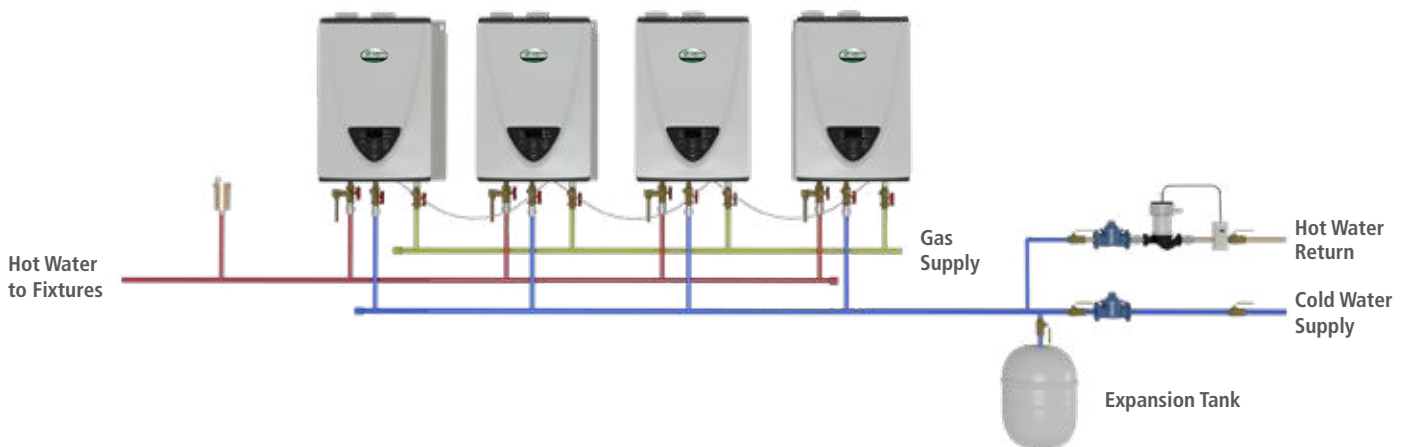

1. Recirculation pump shall be sized for 2-4 gpm per activated heater (4-8 gpm for 910)
2. Recirculation pump shall be controlled by an aquastat. The minimum suggested differential should be 10°F
3. The automatic air should be installed at the highest location of the system in accordance with the manufacturer's instructions.

Multiple Unit with the Multi-Unit Controller

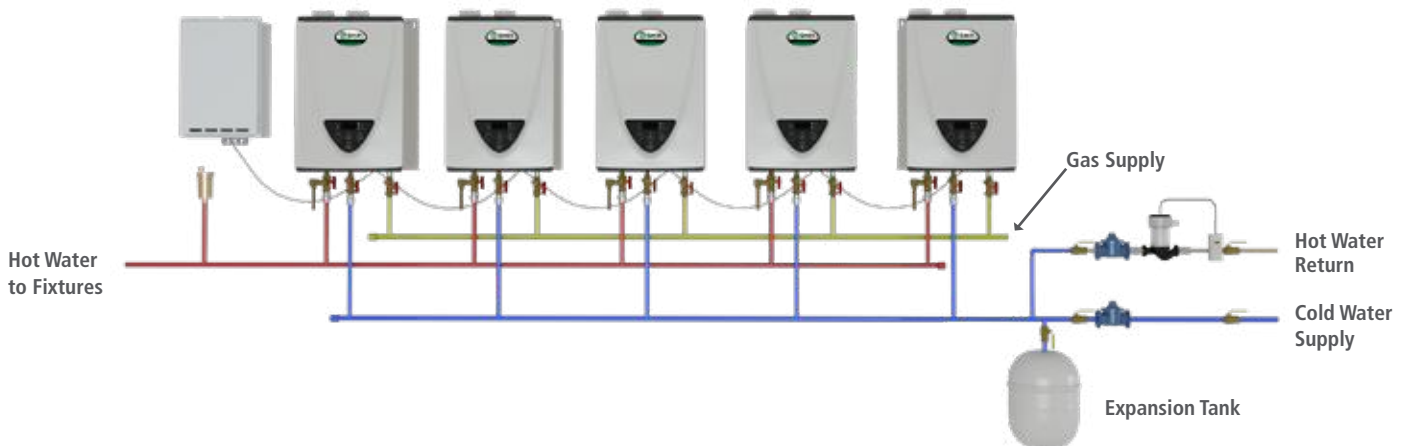

1. Recirculation pump shall be sized for 2-4 gpm per activated heater (4-8 gpm for 910)
2. Recirculation pump shall be controlled by an aquastat. The minimum suggested differential should be 10°F
3. The automatic air should be installed at the highest location of the system in accordance with the manufacturer's instructions.

All application diagrams shown are concept drawings only. These diagrams are only to be used as basic guides. It is up to the application designer to properly design the plumbing layout and correctly size all components within an application (pumps, piping, storage tanks, water heaters, etc.). All national and local codes must be followed and will dictate proper compliance.

MULTI-UNITS

Multiple Unit with Storage

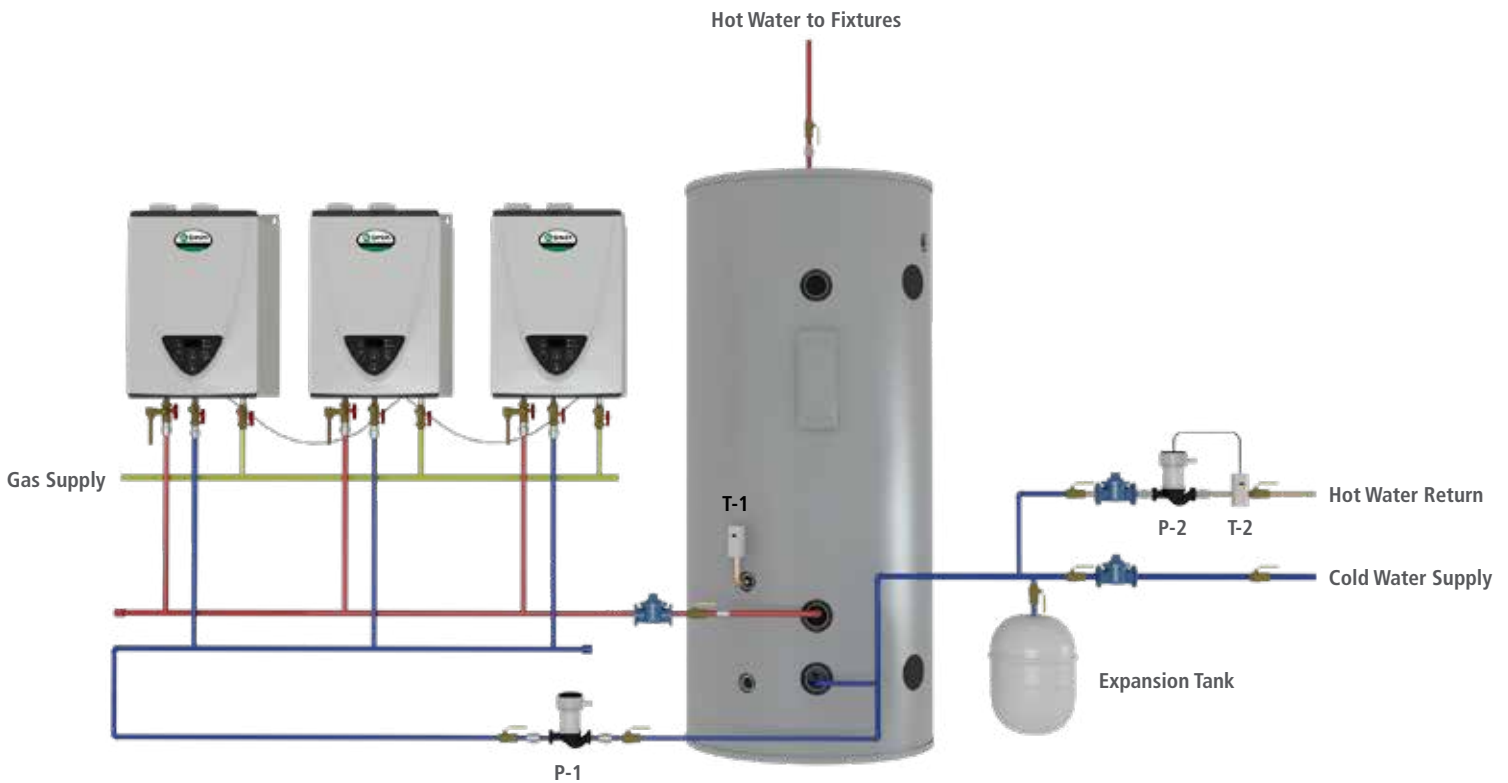

1. Tank circulation pump, P-1, should be controlled by tank aquastat, T-1.
2. Tank aquastat, T-1, should be set 20°F below water heater set temperature.
3. Pump P-1 should be sized to provide flow necessary to heat the storage tank. Refer to the water heater's spec sheet for pressure drop curves.

All application diagrams shown are concept drawings only. These diagrams are only to be used as basic guides. It is up to the application designer to properly design the plumbing layout and correctly size all components within an application (pumps, piping, storage tanks, water heaters, etc.). All national and local codes must be followed and will dictate proper compliance.

SOLAR TANKLESS BACK UP

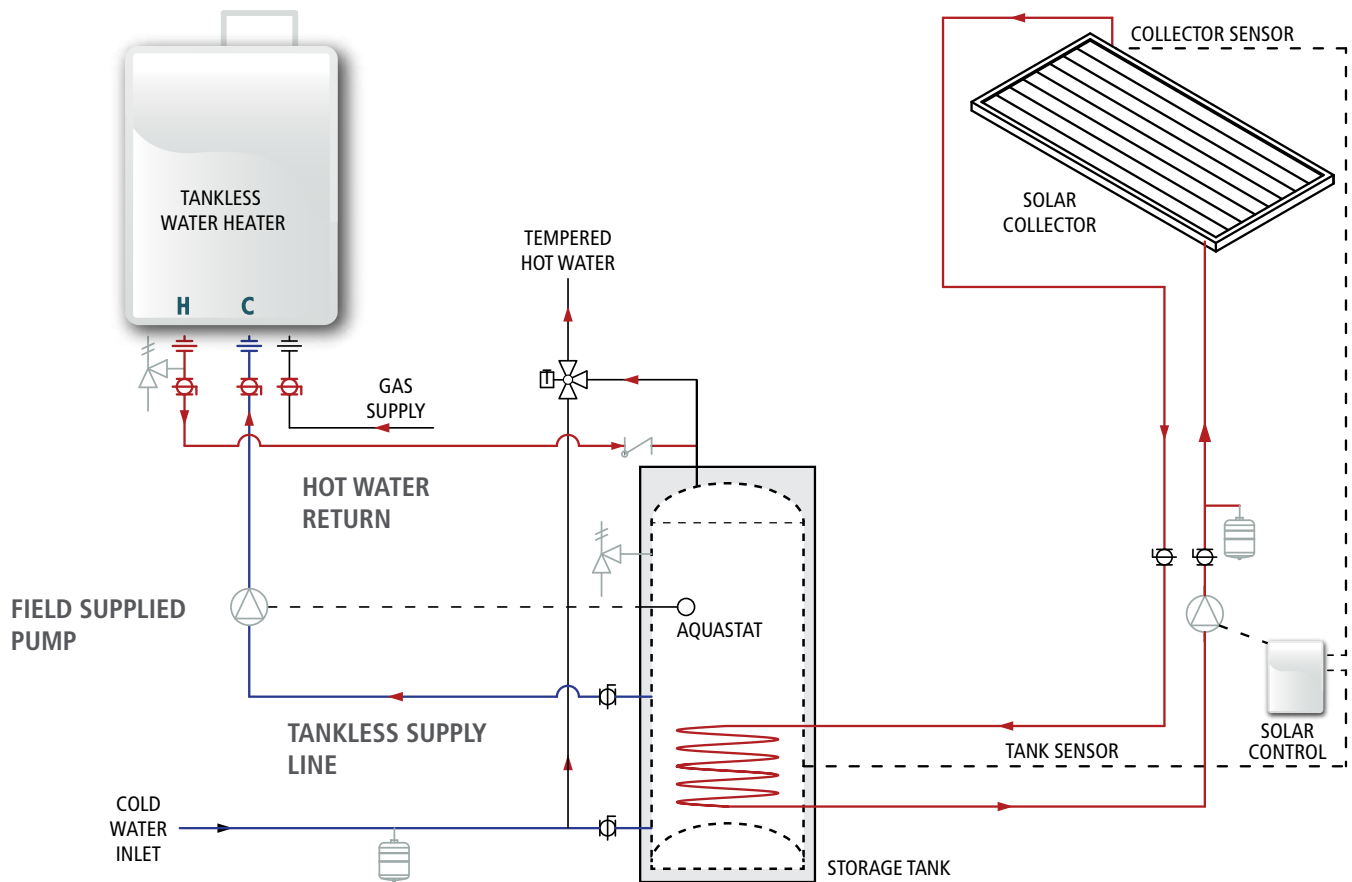

NOTES:

1. Ensure field supplied tank aquastat is in top 1/3 section of the tank.
2. Set tank aquastat 10°F lower than tankless unit set point.
3. Ensure the hot water return from the tankless unit is connected to the hot water outlet from the solar tank as shown in the drawing.
4. The supply line to the tankless unit may be made at the element fitting (after element is removed) with a 1" - 1 1/2 NPSH fitting and gasket.
5. Field supplied pump must provide > 3 GPM flow through tankless backup loop - contact pump manufacturer for sizing assistance.

All application diagrams shown are concept drawings only. These diagrams are only to be used as basic guides. It is up to the application designer to properly design the plumbing layout and correctly size all components within an application (pumps, piping, storage tanks, water heaters, etc.). All national and local codes must be followed and will dictate proper compliance.

VENTING AND ACCESSORIES

Solar Tankless Back Up Diagrams 4" Rooftop Termination

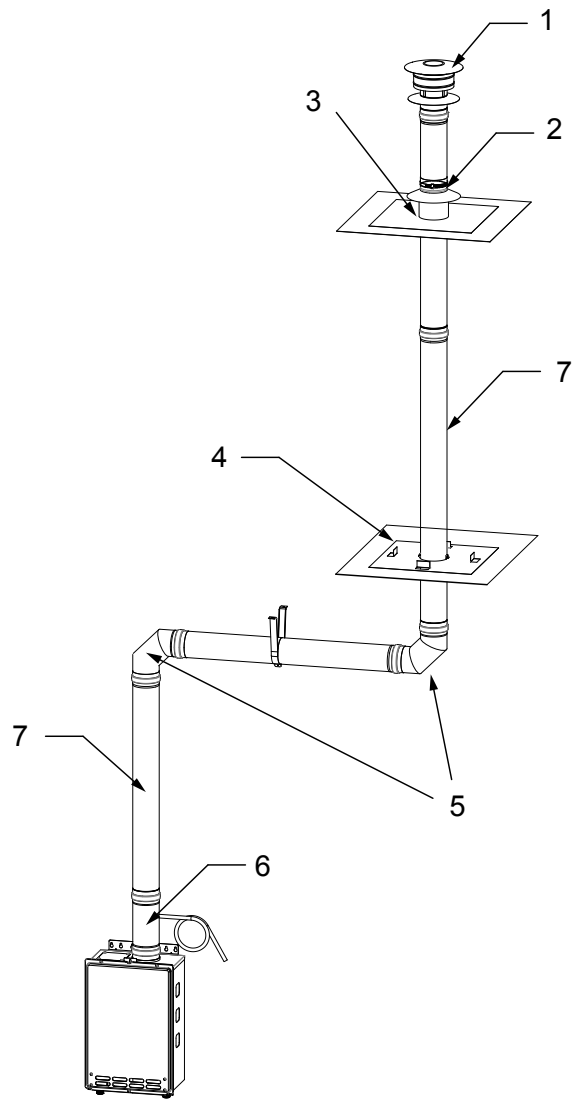

Models 110U, 310U, 510U				Qty.
4" Flat Roof Termination				
Kit Part Number: 100112727	1	100112548	4" Extreme Weather Rain Cap	1
	2	100112410	4" Storm Collar	1
	3	100112412	4" Flat Roof Flashing	1
	4	100112408	4" Vertical Firestop	1
	5	100112400	4" 90 degree Elbow	2
	6	100112549	4" Universal Appliance Adaptor	1
	7	Refer to Accessories Chart	Straight Pipe	TBD

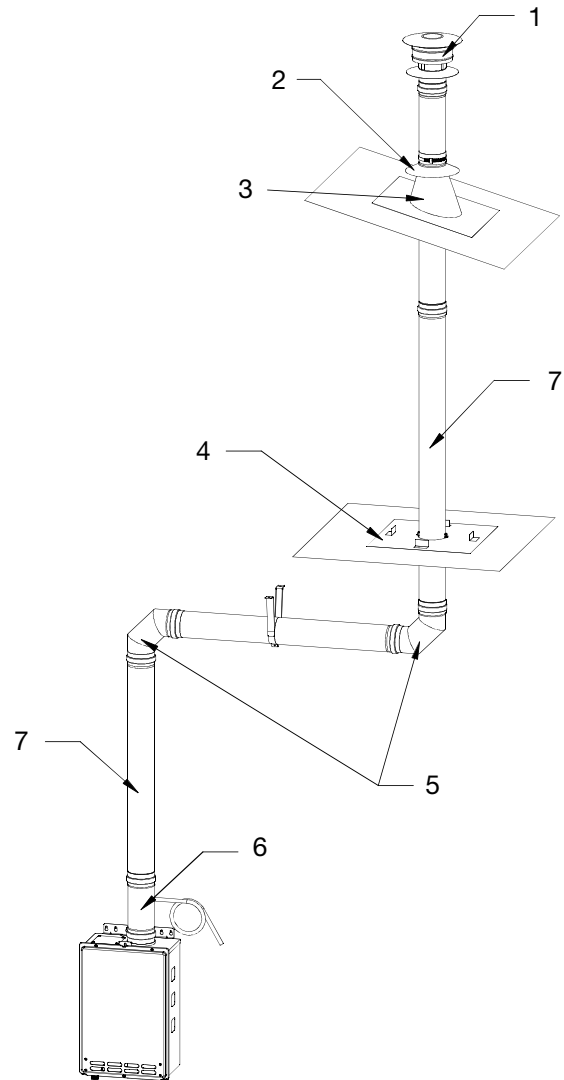

Models 110U, 310U, 510U				Qty.
4" Angled Roof Termination				
Kit Part Number: 100112728	1	100112548	4" Extreme Weather Rain Cap	1
	2	100112410	4" Storm Collar	1
	3	100112411	4" Angled Roof Flashing	1
	4	100112408	4" Vertical Firestop	1
	5	100112400	4" 90 degree Elbow	2
	6	100112549	4" Universal Appliance Adaptor	1
	7	Refer to Accessories Chart	Straight Pipe	TBD

VENTING DIAGRAMS

4" Sidewall Termination

(Please check the wall thickness for proper installation)

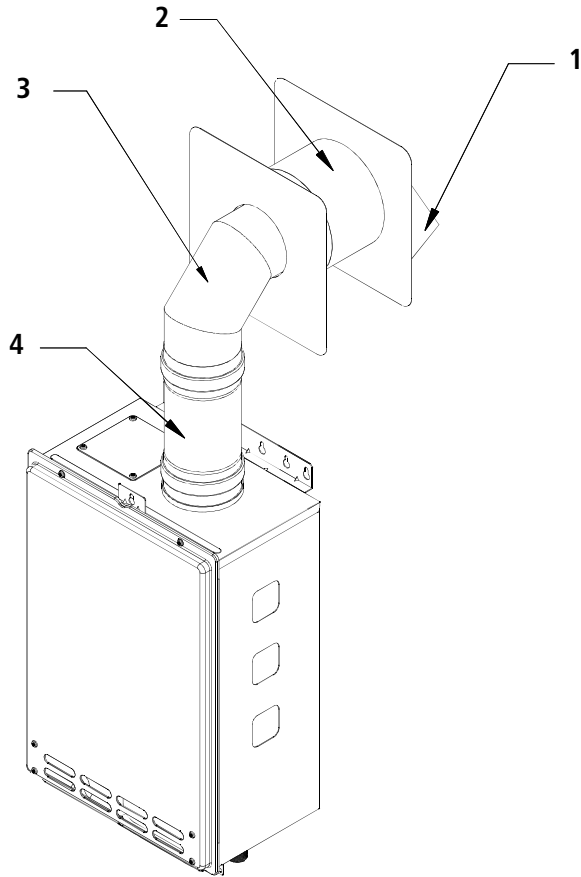

Models 110U, 310U, 510U				Qty.
4" Combustible Sidewall Termination				
Kit Part Number: 100112726	1	100112419	4" Sidewall Hood Terminator	1
	2	100112732	4" Wall Thimble (4.0"-7.0")	1
	3	100112400	4" 90 degree Elbow	1
	4	100112399	4" Female-Female Adaptor	1

Models 110U, 310U, 510U				Qty.
4" Non-Combustible Sidewall Termination				
Kit Part Number: 100112767	1	100112419	4" Sidewall Hood Terminator	1
	2	100112400	4" 90 degree Elbow	1
	3	100112399	4" Female-Female Adaptor	1

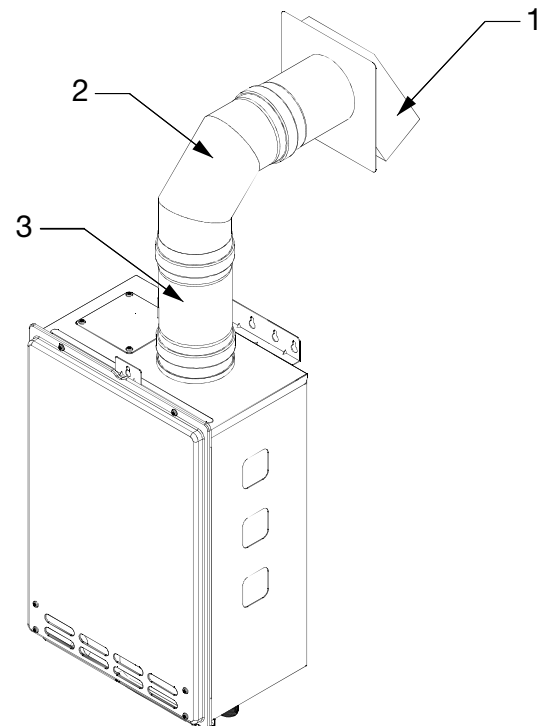

VENTING DIAGRAMS

4" Sidewall Termination (With Condensate Trap)

(Please check the wall thickness for proper installation)

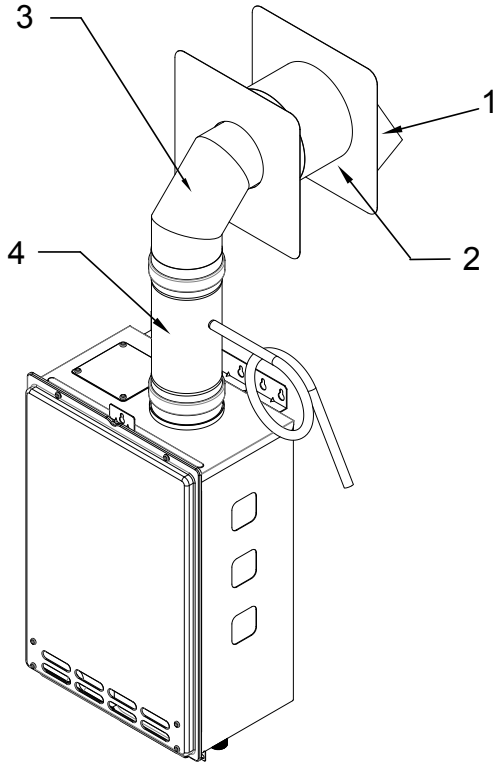

Models 110U, 310U, 510U				Qty.
4" Combustible Sidewall Termination (With Condensate Trap)				
Kit Part Number: 100112775	1	100112419	4" Sidewall Hood Terminator	1
	2	100112732	4" Wall Thimble (4.0"-7.0")	1
	3	100112400	4" 90 Degree Elbow	1
	4	100112549	4" Universal Appliance Adaptor	1

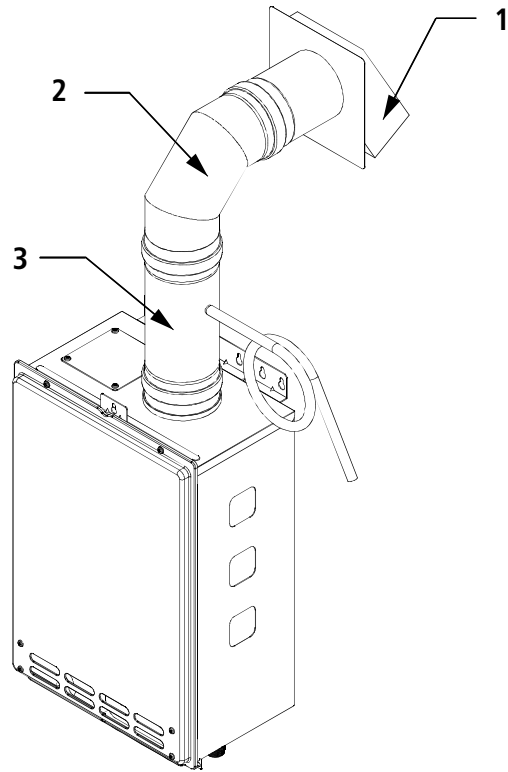

Models 110U, 310U, 510U				Qty.
4" Non-Combustible Sidewall Termination (With Condensate Trap)				
Kit Part Number: 100112776	1	100112419	4" Sidewall Hood Terminator	1
	2	100112400	4" 90 degree Elbow	1
	3	100112549	4" Universal Appliance Adaptor	1

DIRECT VENT, CONCENTRIC SIDEWALL TERMINATION

910 Model

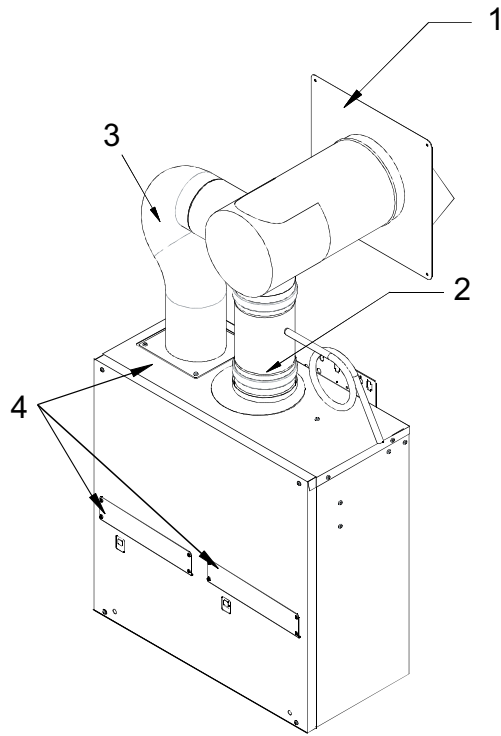

Model 910				Qty.
5-10" Sidewall Thickness Direct Vent, Concentric Termination				
Kit Part Number: 100112606	1	100112604	Concentric Intake/Exhaust Kit	1
	2	100112597	Universal Appliance Adapter	1
	3	NA	5" Aluminum Flex	1
	4	100112186	Direct Vent Conversion Kit	1
12-18" Sidewall Thickness Direct Vent, Concentric Termination				
Kit Part Number: 100112601	1	100112605	Concentric Intake/Exhaust Kit	1
	2	100112597	Universal Appliance Adaptor	1
	3	NA	5" Aluminum Flex	1
	4	100112186	Direct Vent Conversion Kit	1

DIRECT VENT, CONCENTRIC SIDEWALL TERMINATION

5" Sidewall Termination

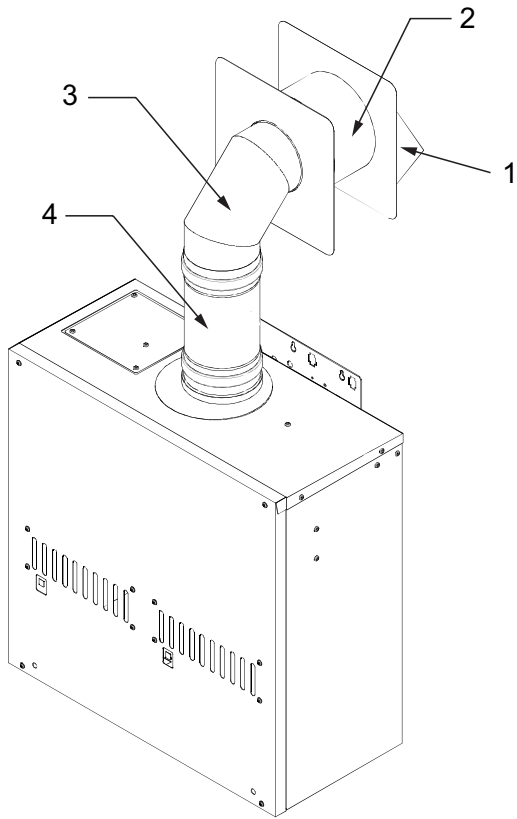

Model 910				Qty.
5" Combustible Sidewall Termination				
Kit Part Number: 100112729	1	100112594	5" Sidewall Hood Terminator	1
	2	100112734	5" Wall Thimble (4.0"-7.0")	1
	3	100112587	5" 90 degree Elbow	1
	4	100112599	5" Female-Female Adaptor	1

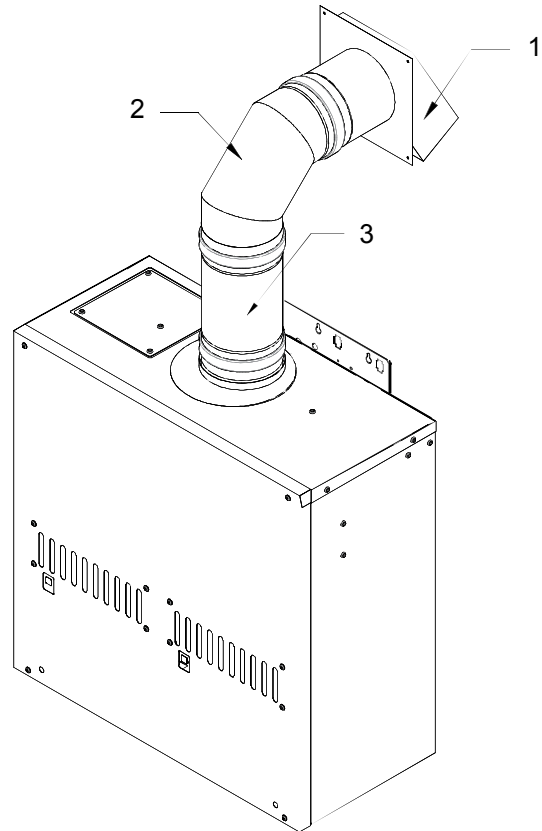

Model 910				Qty.
5" Non-Combustible Sidewall Termination				
Kit Part Number: 100112768	1	100112594	5" Sidewall Hood Terminator	1
	2	100112587	5" 90 degree Elbow	1
	3	100112599	5" Female-Female Adaptor	1

DIRECT VENT, CONCENTRIC SIDEWALL TERMINATION

5" Sidewall Termination (With Condensate Traps)

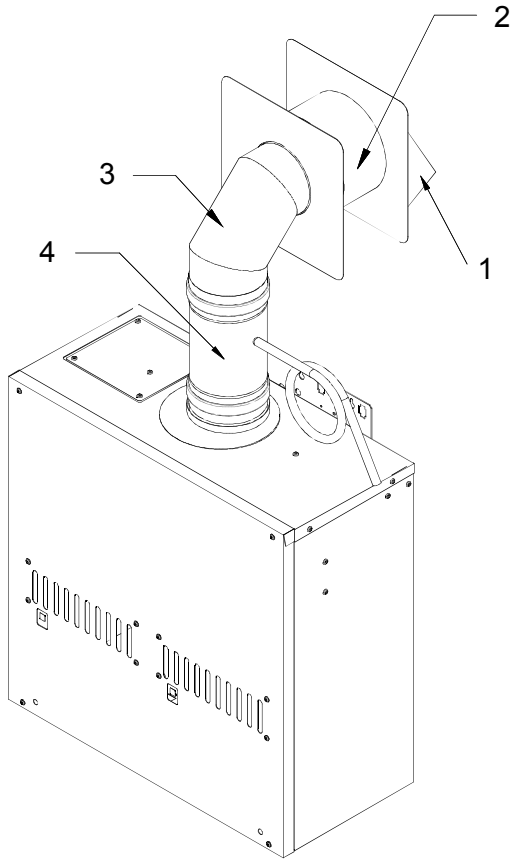

Model 910				Qty.
5" Combustible Sidewall Termination (With Condensate Trap)				
Kit Part Number: 100112777	1	100112594	5" Sidewall Hood Terminator	1
	2	100112734	5" Wall Thimble (4.0"-7.0")	1
	3	100112587	5" 90 degree Elbow	1
	4	100112597	5" Universal Appliance Adaptor	1

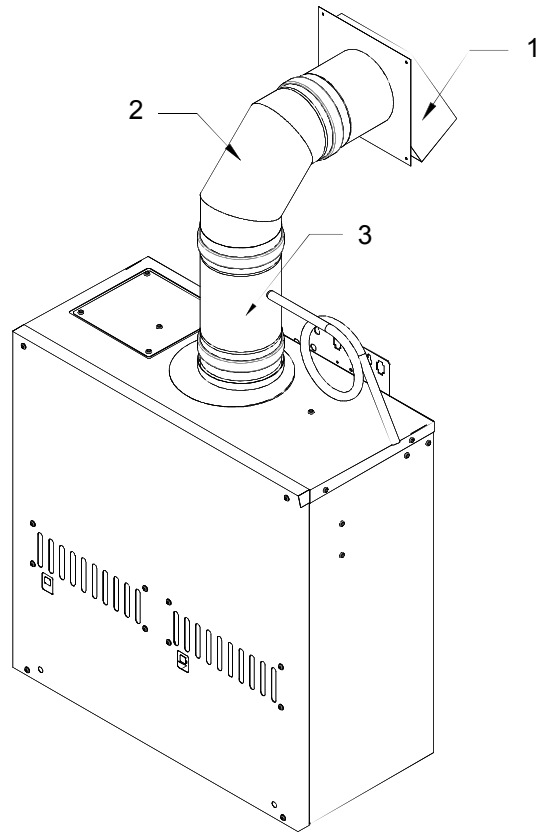

Model 910				Qty.
5" Non-Combustible Sidewall Termination (With Condensate Trap)				
Kit Part Number: 100112778	1	100112594	5" Sidewall Hood Terminator	1
	2	100112587	5" 90 degree Elbow	1
	3	100112597	5" Universal Appliance Adaptor	1

DIRECT VENT, CONCENTRIC SIDEWALL TERMINATION

5" Rooftop Termination

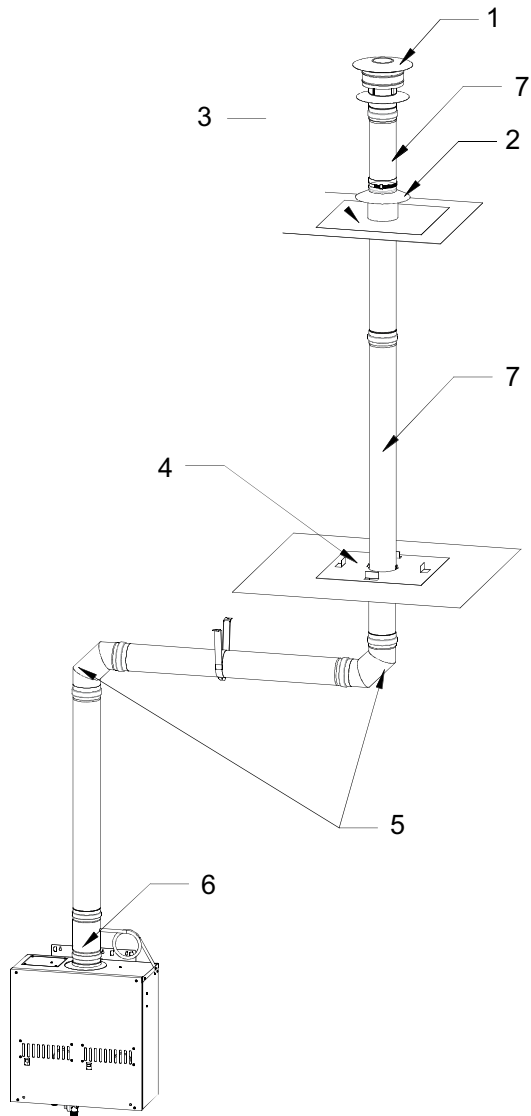

Model 910				Qty.
5" Flat Roof Termination				
Kit Part Number: 100112730	1	100112596	5" Extreme Weather Rain Cap	1
	2	100112590	5" Storm Collar	1
	3	100112592	5" Flat Roof Flashing	1
	4	100112591	5" Vertical Firestop	1
	5	100112587	5" 90 degree Elbow	2
	6	100112597	5" Universal Appliance Adaptor	1
	7	Refer to Accessories Chart	Straight Pipe	TBD

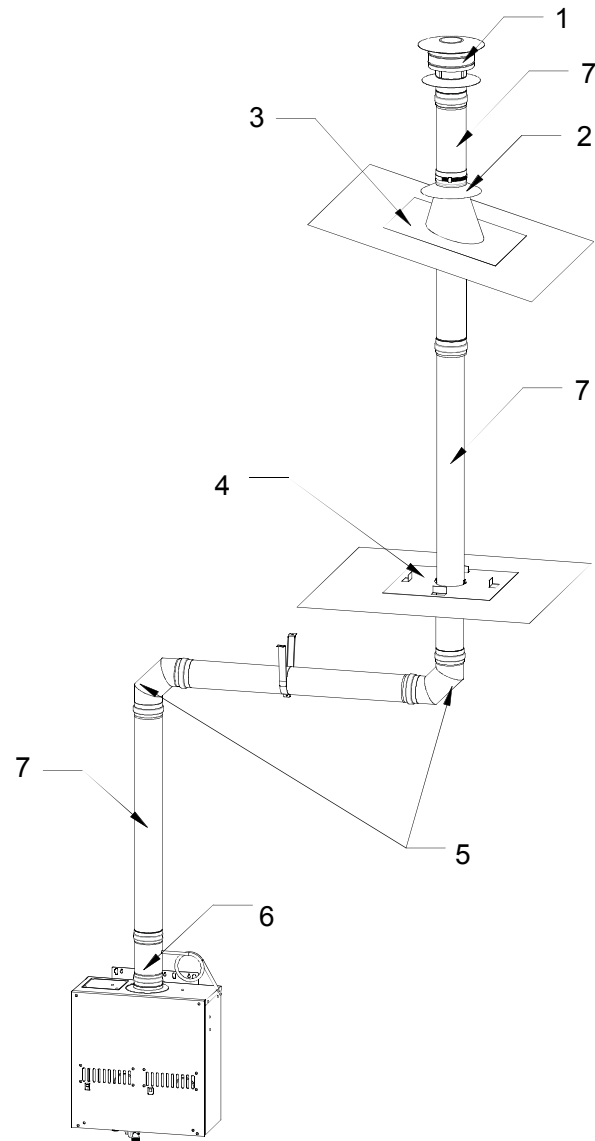

Model 910				Qty.
5" Angled Roof Termination				
Kit Part Number: 100112731	1	100112596	5" Extreme Weather Rain Cap	1
	2	100112590	5" Storm Collar	1
	3	100112593	5" Angled Roof Flashing	1
	4	100112591	5" Vertical Firestop	1
	5	100112587	5" 90 degree Elbow	2
	6	100112597	5" Universal Appliance Adaptor	1
	7	Refer to Accessories Chart	Straight Pipe	TBD

CONCENTRIC VENT SERIES

Horizontal Installation

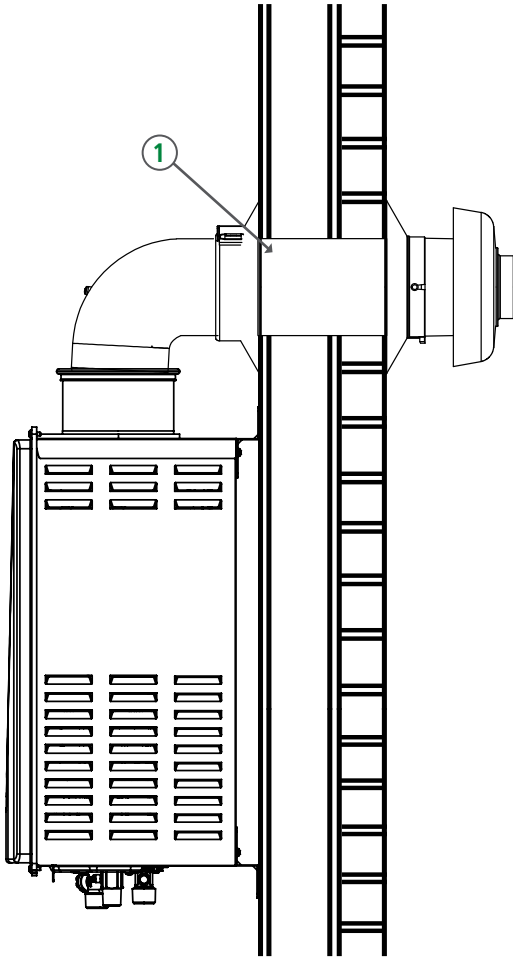

Models 310C, 510C

1	Standard Sidewall Kits*	100322374 (11.5")
		100322375 (21")
2	Straight Pipe	100266133 (10")
		100266134 (19.5")
		100266135 (39")
3	Elbow	100266119 (45°)
		100266132 (87°)
4	Condensate Collector	100266139
5	Condensate Trap	100266140
6	Flue Adapter	100322379

*This kit includes one 87° elbow and Flue Adapter.

Horizontal Installation

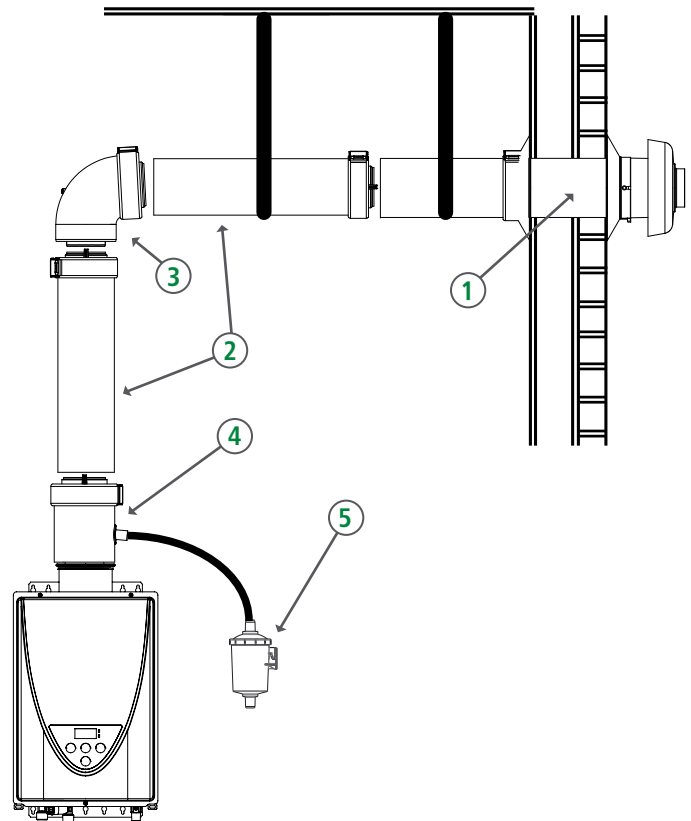

CONCENTRIC VENT SERIES

Vertical Installation

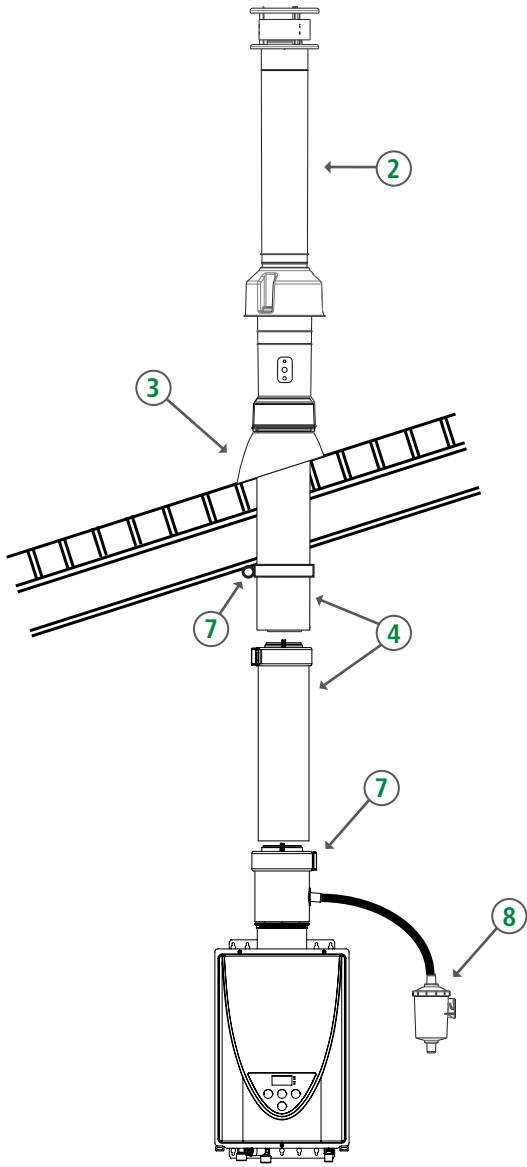

Vertical Installation

Models 310C, 510C

	Roof Termination (38")	100305170
2	Roof Termination (38")	100266118
3	Tile/Shingle Roof Flashing	100266136 (1/12 to 6/12 pitch)
		100266137 (8/12 to 16/12 pitch)
		100266138 (6/12 to 12/12 pitch)
		100266187 (Flat Roof)
4	Straight Pipe	100266133 (10")
		100266134 (19.5")
		100266135 (39")
5	Pipe Hangers	100266141
6	Elbow	100266119 (45°)
		100266132 (87°)
7	Condensate Collector	100266139
8	Condensate Trap	100266140

Vertical Installation

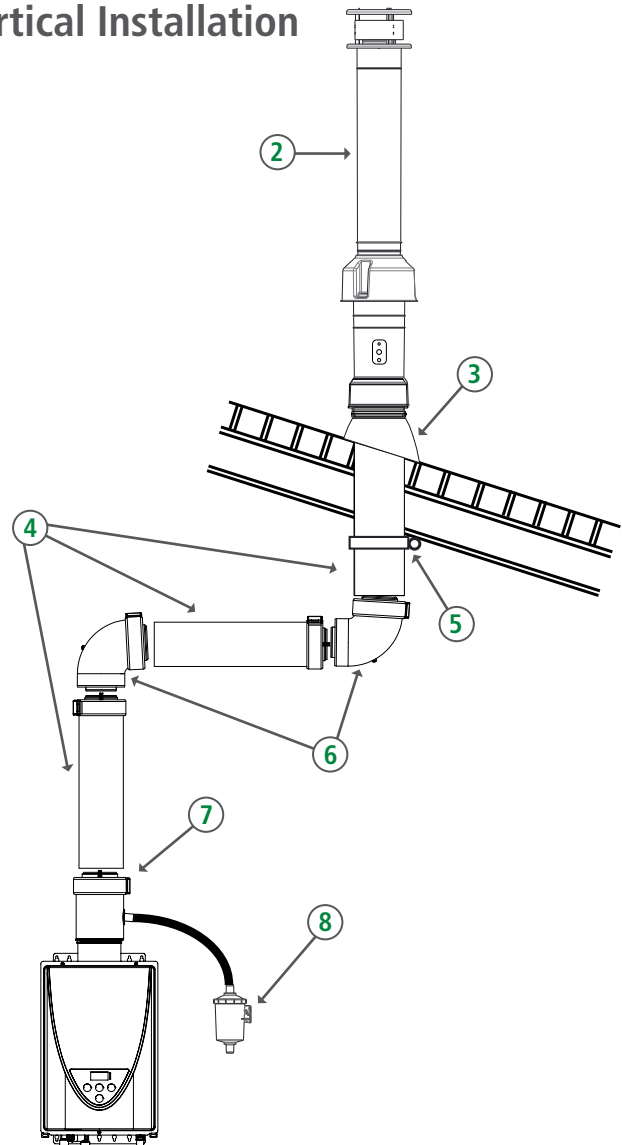

VENTING COMPONENTS

Simple Leak-Proof Gasketed Connections – No Sealant Required. High Quality – Category III / IV Stainless Steel.
 Versatile – Vertical and Horizontal Terminations. Convenient – Vent Kits Available.
 UL Listed. All Connections have Heat-Resistant Rubber Gaskets.

Nova Vent Part #	Description	
Straight Vent Pipe		
100112407	4" Straight pipe - 6" Length	
100112406	4" Straight pipe - 12" Length	
100112404	4" Straight pipe - 24" Length	
100112403	4" Straight pipe - 36" Length	
100112402	4" Straight pipe - 48" Length	
100112580	5" Straight pipe - 6" Length	
100112581	5" Straight pipe - 12" Length	
100112582	5" Straight pipe - 24" length	
100112583	5" Straight pipe - 36" Length	
100112584	5" Straight pipe - 48" Length	
Adjustable Vent Pipe		
100112405	4" Adjustable Pipe (7" - 9.9")	
100112585	5" Adjustable Pipe (7" - 9.9")	
Elbow		
100112401	4" 45 Degree Elbow	
100112586	5" 45 Degree Elbow	
100112400	4" 90 Degree Elbow	
100112587	5" 90 Degree Elbow	
Adaptor		
100112399	4" Female-Female Adaptor	
100112599	5" Female-Female Adaptor	
100112549	4" Universal Appliance Adaptor 3-in-1 (F-F adaptor, condensate drain, & back-flow preventer)	
100112597	5" Universal Appliance Adaptor 3-in-1 (F-F adaptor, condensate drain, & back-flow preventer)	

Nova Vent Part #	Description	
Backflow Preventer		
100112416	4" Backflow Preventer & F-F Adaptor	
100112598	5" Back-flow Preventer & F-F Adaptor	
Condensation Drain		
100112414	4" Horizontal Drain Tee	
100112588	5" Horizontal Drain Tee	
100112413	4" Vertical Drain Tee	
100112589	5" Vertical Drain Tee	
Support		
100112409	4" Support Strap (1")	
100112600	5" Support Strap (1")	
Wall Thimble		
100112732	4" Wall Thimble (4"-7")	
100112733	4" Wall Thimble (5"-10")	
100112734	5" Wall thimble (4"-7")	
100112735	5" Wall thimble (5"-10")	
4" Sidewall Termination & Thimble Kit		
100112424	Sidewall Vent Terminator (Hood) and Wall Thimble (4"-7")	
100112425	Sidewall Vent Terminator (Hood) and Wall Thimble (5"-10")	

Note: 110U, 140H, 310U, 510U, 240H/X3, 340H/X3, 540H/P/X3 series are compatible with 4" components. 910 series is compatible with 5" components.

VENTING COMPONENTS











Nova Vent Part #	Description	
Termination		
100112547	4" Termination Tee	
100112595	5" Termination Tee	
100112419	4" Exhaust Sidewall Vent Terminator (Hood)	
100112594	5" Exhaust Sidewall Vent Terminator (Hood)	
100112415	4" Rain Cap	
100112548	4" Extreme Weather Rain Cap	
100112596	5" Extreme Weather Rain Cap	
100112163	3" Concentric PVC Termination	
Firestop		
100112408	4" Firestop	
100112591	5" Firestop	
Roof Flashing		
100112412	4" Flat Roof Flashing	
100112592	5" Flat Roof Flashing	
100112411	4" Angled Roof Flashing	
100112593	5" Angled Roof Flashing	
Storm Collar		
100112410	4" Storm Collar	
100112590	5" Storm Collar	
Direct Vent Conversion Kit		
100112186	Direct Vent Conversion Kit for Model 910	

Nova Vent Part #	Description	
Intake Hood (Galvanized)		
100112545	3"	
100112546	4"	
100112547	5"	

Direct Vent, Concentric Sidewall Termination Kit		
100112421	5.0" to 10.0" 3" Intake, 4" Exhaust	
100112420	12.0" to 18.0" 3" Intake, 4" Exhaust	
100112602	5.0" to 10.0" 4" Intake, 4" Exhaust	
100112603	12.0" to 18.0" 4" Intake, 4" Exhaust	
100112606	5.0" to 10.0" 5" Intake, 5" Exhaust	
100112601	12.0" to 18.0" 5" Intake, 5" Exhaust	

Note: 110U, 140H, 310U, 510U, 240H/X3, 340H/X3, 540H/P/X3 series are compatible with 4" components. 910 series is compatible with 5" components.

ACCESSORIES









	Description		ATI-110U	ATO-110U	ATI-310C	ATI-310U	ATO-310U	ATI-510C	ATI-510U	ATO-510U	ATI-140	ATO-140	ATI-240/X3	ATO-240/X3	ATI-340/X3	ATO-340/X3	ATI-540/X3	ATO-540/X3	ATO-910	ACT-199I/O	ATI-540P	ATO-540P		
100112194	Outdoor Vent Cap																		X					
100266729, 100266730	Recess Box Retrofit New Construction			X			X			X		X												
100112188	Pipe Cover		X	X																				
100324434			X	X		X	X		X	X														
100112190																				X				
100112718														X	X	X	X	X	X			X	X	X
100187904												X	X											
100112691	Multiple Unit Controller							X	X*	X*							X**	X**	X	X				
100112183	Remote Temperature Controller		X	X		X	X																	
100112155									X	X										X				
100209924			X*	X*	X	X*	X*	X	X*	X*	X	X	X	X	X	X	X	X	X					
100276687																							X	X
100112572																					X			
100112156	Isolation Valves (Lead Free)		X	X	X	X	X	X	X	X	X	X	X	X	X	X	X	X	X	X	X	X	X	
100112159	Neutralizer										X	X	X	X	X	X	X	X		X	X	X		
100113129	PVC Adapter for Common Venting												X		X		X			X	X			
100113130	Non-Return Valve for Common Venting												X		X		X			X	X			
100291509	Product Preservers® Anti-Scale System		X	X	X	X	X	X	X	X	X	X	X**	X**	X**	X**	X**	X**	X	X	X	X	X	
100291510	Product Preservers Replacement Cartridge		X	X	X	X	X	X	X	X	X	X	X**	X**	X**	X**	X**	X**	X	X	X	X	X	

*Compatible with Ultra-Low NOx models only
 **Non-X3 models

PRODUCT OVERVIEW

I = Indoor O= Outdoor		Connection: Gas/Water Power	Venting Intake Exhaust	EASY-LINK™ (EL) Multi-Unit (MU)	Temperature	GPM (Max) Per Unit	Uniform Energy Factor	Max BTU/h	Dimension/ Weight	
Residential Non-Condensing	310C Series  ATI-310C-N	Ideal for 2 to 3 bath homes	3/4" Gas/Water 120 VAC	3" / 5" Concentric, 43' Max	N/A	100 - 140 °F	8.0	0.81	190,000	H= 20-1/2" W= 13-3/4" D= 11-1/2" 51 lbs
	510C Series  ATI-510C-N	Well suited for light commercial applications. Commercial-grade copper	3/4" Gas/Water 120 VAC	3" / 5" Concentric, 43' Max	(EL) 4 units (MU) 20 unit	100 - 160 °F	10.0	0.81	199,000	H= 20-1/2" W= 13-3/4" D= 11-1/2" 51 lbs
	110U Series  ATI-110U	Great for apartments, condos and summer cabins.	3/4" Gas/Water 120 VAC	I Model: 3" Intake, 60' Max 4" Exhaust, 60' Max	N/A	100 - 140 °F	6.6	I: 0.81 O: 0.81	140,000	H= 20-1/2" W= 13-3/4" D= 10" 38 lbs
	310U Series  ATI-310U	Ideal for 2 to 3 bath homes	3/4" Gas/Water 120 VAC	I Model: 3" Intake, 60' Max 4" Exhaust, 60' Max	N/A	100 - 140 °F	8.0	I: 0.81 O: 0.81	190,000	H= 20-1/2" W= 13-3/4" D= 10" 38 lbs
	510U Series  ATI-510U	Well suited for light commercial applications. Commercial-grade copper	3/4" Gas/Water 120 VAC	I Model: 3" Intake, 60' Max 4" Exhaust, 60' Max	(EL) 4 units (MU) 20 units	100 - 160 °F	10.0	I: 0.81 O: 0.81	199,000	H= 20-1/2" W= 13-3/4" D= 10" 40 lbs
Commercial	910 Series  ATIO-910	Generates Most GPM in tankless industry. 14.5 GPM (Max). Commercial-grade copper alloy. LED display	1" Gas/Water 120 VAC	5" Intake, 50' Max 5" Exhaust, 50' Max	(EL) 4 units (MU) 10 units	100 - 185 °F	14.5 (Up to 145 GPM max with 10 unit system)	Thermal Efficiency NG: 80.2% LP: 82.4%	380,000	H= 25-1/4" W= 24-3/4" D= 11-3/4" 113 lbs
	CT-199 Series  ACT-199I	High efficiency ultra-low NOx condensing tankless. 3" PVC venting. 0" clearance to combustible.	3/4" Gas/Water 120 VAC	Intake & Exhaust 3", 70' Max, 5 elbow Max OR 4", 100' Max, 5 elbow Max	(EL) 4 units (MU) 20 units	100 - 185 °F	10.0 (Up to 200 GPM max with 20 unit system)	Thermal Efficiency 96% I: 0.93 O: 0.95	199,000	H = 23-5/8" W = 17-3/4" D = 11-1/4" 59 lbs

PRODUCT OVERVIEW

I = Indoor O= Outdoor			Connection: Gas/Water Power	Venting Intake Exhaust	EASY-LINK™ (EL) Multi-Unit (MU)	Temperature	GPM (Max) Per Unit	Uniform Energy Factor	Max BTU/h	Dimension/ Weight
Residential Condensing	140H Series  ATI-140 ATO-140	High efficiency ultra-low NOx condensing tankless. 3" PVC venting. 0" clearance to combustible.	1/2" Gas 3/4" Water 120 VAC	Intake & Exhaust 3", 70' Max, 5 elbow Max OR 4", 100' Max, 5 elbow Max	N/A	100 - 140 °F	7.0	I: 0.90 O: 0.91	120,000	H = 22-7/8" W = 13-7/8" D = 10-3/4" 50 lbs
	240H Series  ATI-240 ATO-240	High efficiency ultra-low NOx condensing tankless. 3" PVC venting. 0" clearance to combustible.	3/4" Gas/Water 120 VAC	Intake & Exhaust 3", 70' Max, 5 elbow Max OR 4", 100' Max, 5 elbow Max	N/A	100 - 140 °F	6.6	I: 0.94 O: 0.95	160,000	H = 23-5/8" W = 17-3/4" D = 11-1/4" 58 lbs
	340H Series  ATI-340 ATO-340	High efficiency ultra-low NOx condensing tankless. 3" PVC venting. 0" clearance to combustible.	3/4" Gas/Water 120 VAC	Intake & Exhaust 3", 70' Max, 5 elbow Max OR 4", 100' Max, 5 elbow Max	N/A	100 - 140 °F	8.0	I: 0.95 O: 0.94	180,000	H = 23-5/8" W = 17-3/4" D = 11-1/4" 58 lbs
	540H Series  ATI-540 ATO-540	High efficiency ultra-low NOx condensing tankless. 3" PVC venting. 0" clearance to combustible.	3/4" Gas/Water 120 VAC	Intake & Exhaust 3", 70' Max, 5 elbow Max OR 4", 100' Max, 5 elbow Max	(EL) 4 units (MU) 20 units	100 - 160 °F	10.0	I: 0.93 O: 0.95	199,000	H = 23-5/8" W = 17-3/4" D = 11-1/4" 59 lbs
	540P Series  ATI-540P ATO-540P	High efficiency ultra-low NOx condensing tankless with integrated recirculation pump.	3/4" Gas/Water 120 VAC	Intake & Exhaust 3", 70' Max, 5 elbow Max OR 4", 100' Max, 5 elbow Max	(EL) 4 units	100 - 140 °F	10.0	I: 0.93 O: 0.95	199,000	H = 23-5/8" W = 17-3/4" D = 11-1/4" 61 lbs
	240HX3 Series  ATI-240HX3 ATO-240HX3	High efficiency ultra-low NOx condensing tankless. 3" PVC venting. 0" clearance to combustible.	3/4" Gas/Water 120 VAC	Intake & Exhaust 3", 70' Max, 5 elbow Max OR 4", 100' Max, 5 elbow Max	N/A	100 - 140 °F	6.6	I: 0.94 O: 0.95	160,000	H = 23-5/8" W = 17-3/4" D = 11-1/4" 58 lbs *cabinet only
	340HX3 Series  ATI-340HX3 ATO-340HX3	High efficiency ultra-low NOx condensing tankless. 3" PVC venting. 0" clearance to combustible.	3/4" Gas/Water 120 VAC	Intake & Exhaust 3", 70' Max, 5 elbow Max OR 4", 100' Max, 5 elbow Max	N/A	100 - 140 °F	8.0	I: 0.95 O: 0.94	180,000	H = 23-5/8" W = 17-3/4" D = 11-1/4" 58 lbs *cabinet only
	540HX3 Series  ATI-540HX3 ATO-540HX3	High efficiency ultra-low NOx condensing tankless. 3" PVC venting. 0" clearance to combustible.	3/4" Gas/Water 120 VAC	Intake & Exhaust 3", 70' Max, 5 elbow Max OR 4", 100' Max, 5 elbow Max	N/A	100 - 160 °F	10.0	I: 0.93 O: 0.95	199,000	H = 23-5/8" W = 17-3/4" D = 11-1/4" 59 lbs *cabinet only



500 Tennessee Waltz Pkwy
Ashland City, TN 37015
Toll Free: 877.737.2840